



Fabric Expansion Joint





Fabric Expansion Joint

Table of Contents



Introduction to Kurbo	1
Why Use Kurbo Fabric Expansion Joint?	3
Basic Types of Fabric Expansion Joint	5
Typical Kurbo Expansion Joint Component	7
Basic Frame Design	9
Basic Liner Baffle Design	11
Engineering Design Concept of Kurbo Expansion Joint	13
Construction of Kurbo Typical Flexible Belt Elements	17
Expansion Joint Specification Sheet	19
Complete Line of Kurbo Expansion Joints	20



INTRODUCTION TO KURBO

Reborn Company of Kurbo

In 1996, Kurbo Company Limited was established to design, manufacture and supply rubber expansion joints for a broad range of Industries and now it has been known as leading manufacturer in Korea and Asia. Substantial exports have been delivered to over 20 countries. Since 2010, not a few our customers who have purchased our rubber expansion joints for over 10 years and have been very familiar with our competitive priority-service, quality and reliability have asked us to supply metal expansion joints and fabric expansion joints as well, in which we are encouraged to start building metal and fabric expansion joints and are sailing around the world.



Rectangular corner molding process



*Integrally flanged type expansion joints
with metal frame and baffle before fabrication of
flexible elements*

Manufacturing and Design Capability

Now we design and manufacture a full range of fabric expansion joints, including single layer type and composite type in either the “Belt type” or “Integrally flanged type”. A variety of lay-ups of composite belts are available depending upon system temperature and corrosive media etc. Kurbo provide so many different types and shapes of metal frame that can be applied to different application and it also has different baffle liner design to protect the flexible element and insulation pillow from fly ash accumulation and abrasion.

There are many important aspects to the design of the expansion joint flexible element. Kurbo product engineers have made a particular study of materials. Selection of the correct one from so many different materials available is the vital factor in obtaining the optimum resistance to temperature, pressure, corrosion and erosion and the longest possible expansion joint cycle life.

Kurbo designs and manufactures its fabric expansion joint to international standard and reference such as ASME, EJMA. Kurbo also adopts Fluid Sealing Association (FSA) and European Sealing Association (ESA) for ducting system for non-metallic expansion joint in its fabrication / lay-up process.

Quality Assurance

Kurbo works to an approved quality assurance / quality control procedure manual. This dedication to quality is reflected in the performance of Kurbo products

With full range of manufacturing, engineering and testing capabilities, Kurbo can provide full quality assurance that its products meet customers' needs.



8000mm diameter integrally flanged type fabric expansion joint



WHY USE KURBO FABRIC EXPANSION JOINT?



What is Kurbo Fabric Expansion Joint?

Kurbo fabric expansion joints are designed to provide stress relief in ducting systems by absorbing movement caused by thermal changes. They also act as vibration isolators, shock absorbers and make up for minor misalignments of adjoining ducting or equipment. They are fabricated from a wide variety of non-metallic materials, including synthetic elastomers, fabrics, insulation materials and fluoroplastics, depending on the designs.

Industry Application

Kurbo fabric expansion joints with the competitive advantage mentioned above against metallic expansion joints are widely used in many industries which convey gases such as following application/system

Application

- Power Generations
- Pulp and Paper Plants
- Foundries
- Cement Plants
- Food Processing and many others
- Refineries
- Steel Mill
- Smelters
- Incinerators

System

- Gas turbine exhausts
- Heat recovery
- Stack hot air
- Scrubber
- Air pollution and fume control
- Exhaust gas and air
- Precipitator
- Flue gas duct
- Baghouse
- Low pressure process gas and air



Features

• Large Movements:

Kurbo fabric expansion joints offer multi-plane movement in a shorter face to face dimension. The ability to accommodate axial, lateral, torsional and angular movements concurrently is an inherent capability of Kurbo fabric expansion joints designs

• Low Loads:

The spring rates generated by the movements or required to move the expansion joints are very low.

• Corrosion Resistance :

Kurbo fabric expansion joint's use of the wide variety of elastomers, fabrics and fluoroplastics allows the selection of the correct materials for each application. The superior corrosion resistance of flexible rubbers and fluoroplastics can extend the life of the expansion joint

• Sound and Vibration Elimination:

The outstanding vibration and sound attenuation characteristics of elastomers help prevent premature system degradation.



- **High Temperature:**

With the use of special materials, Kurbo fabric expansion joints can withstand over 1000°C operating temperatures

- **No Gaskets Required:**

Since most installations are either welded into place or use integral rubber flanges, the use of gaskets may not be required (For those installations utilizing metal flanges bolted into place, gaskets will be required.).



Benefits

- **Lower System Design Costs:**

Since Kurbo fabric expansion joints can accommodate all of the types of movements concurrently, the resultant system cost can be reduced as follows:

- The number of total expansion joints may be reduced to take advantage of the large, multi-plane movements.
- The same movements can be derived in shorter face-to-face dimensions than metal expansion joints.
- The system geometry can be simplified.
- The use of costly toggles, hangers, support structures and guides can be extensively reduced.
- The engineering time required to design the system is significantly reduced.

- **Low Material Costs:**

The use of high alloy metals may not be required to meet the corrosion resistance required by the application. The variety of elastomers and plastics available will allow the selection of the precise, least expensive material.

- **Lower Shipping and Installation Costs:**

Kurbo fabric expansion joint can be factory pre-assembled and shipped to the jobsite for ease of installation. They are relatively light weight and can be hoisted into place with a minimum of field assembly required.

- **Lower Replacement Cost:**

Changing Kurbo fabric expansion joints can be done with a minimum of downtime. The expansion joint can be provided either factory spliced or open ended for field splicing.



BASIC TYPES OF FABRIC EXPANSION JOINT

Single Layer Type

This type is comprised of one or more reinforcement plies with non-permeable laminates to form a homogeneous material impervious to flue gases and very resistant to flue gas acids, oils, chemicals, and heat. Single layer belts are offered in either elastomer, fluoroelastomer or PTFE. Maximum operating temperature to 250°C.



Composite Type

This type of expansion joint consists of various layers of materials which are usually bonded, knitted, sewn or bolted together in the clamped flange area. Composite belts include gas seal membrane, insulating layer, retaining layer, wire mesh, coated fabric reinforcing plies and other layers or barriers. Composite belts are manufactured in either Belt type or Integrally Flanged type. Maximum operating temperature to 1300°C.



Kurbo's fabric expansion joint designs will fall into two basic types; single layer type or composite type. Within the two basic types, Kurbo's fabric expansion joint is manufactured either in a belt type or integral molded flange type.

An important consideration in selecting Kurbo's fabric expansion joint is the system temperature. In general, there are two classifications: those operating under 200°C (typically elastomeric) and those operating above 200°C (typically composite)

Belt Type Expansion Joint

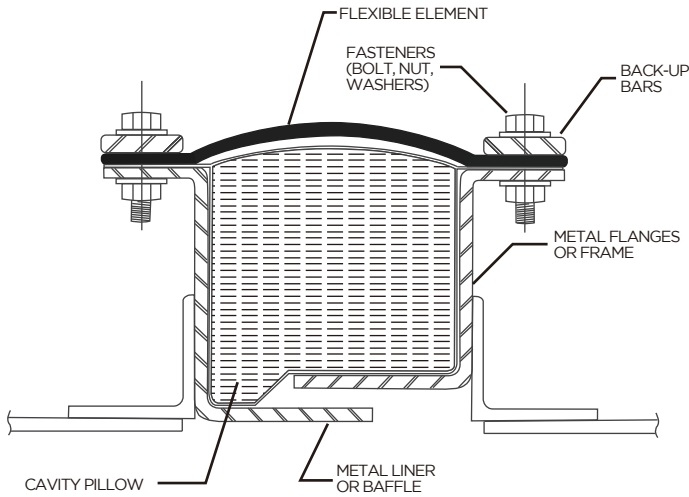

Integrally Flanged Type Expansion Joint

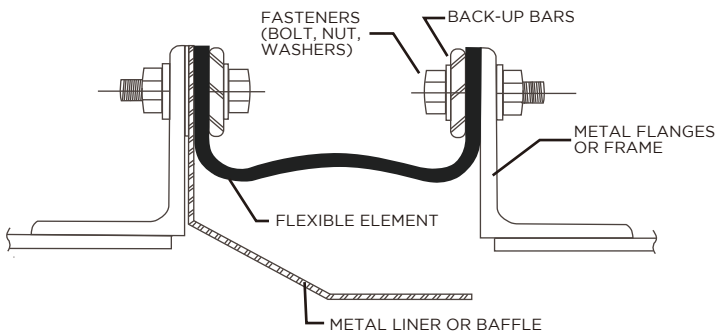

TYPICAL KURBO EXPANSION JOINT COMPONENTS

1 Gas Seal Membrane

The gas seal membrane is the outermost layer of the expansion joint flexible element and is designed to withstand system pressure and resist chemical attack. The gas seal membrane should have the flexibility to absorb thermal movements. Based on system temperatures, the gas seal membrane may stand alone or be combined with additional thermal barriers

2 Insulating Layers

The insulating layers provide a thermal barrier to ensure that the inside surface temperature of the gas seal membrane does not exceed its maximum service temperature. This insulating layer (in combination with a secondary gas seal membrane) also reduces the chance of hot flue gas condensing on the inside of an uninsulated gas seal membrane

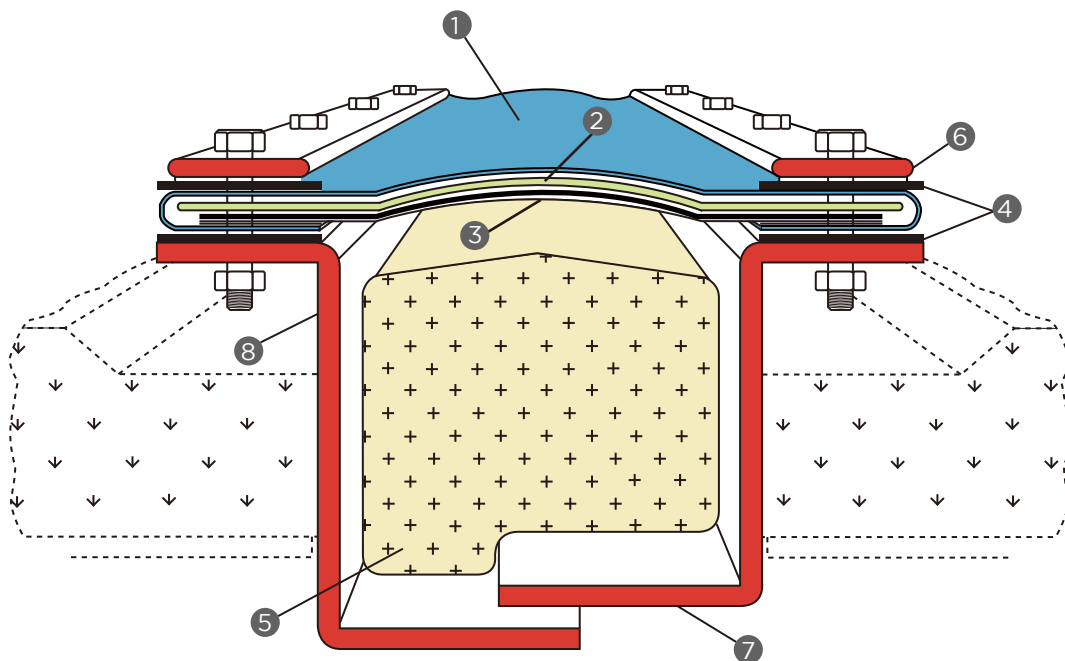

3 Insulating Retainer Layer

This insulating retainer layer is provided to protect the insulating layers in place in order to maintain thermal integrity. The retaining layer is selected based on the operating temperature and chemical compatibility.

4 Gasket

The flange gasket or cuff protects the gas seal membrane on a multi-layered flexible element from thermal degradation caused by hot metal flanges and back-up bars. Due to low 'Coefficient of Friction' property of fluoroplastics, a flexible, chemically inert gasket is required between the metal attachment flange and the gas seal membrane in order to provide an adequate seal.

5 Insulation / Accumulation Pillow

Insulation and accumulation pillows fill the cavity between the flexible element and metal liner and are used to prevent the accumulation of particulate matter from being trapped in the expansion joint cavity. It is typically used in duct from boilers to air clean-up equipment such as precipitators, scrubber and bag houses or whenever large amount of dust/ash are present in the gas

6 Back-Up Bars

The back-up bars are used to seal the flexible element against the metal frame. Back-up bar selection depends on bolt spacing, bolt hole size and flange height of expansion joint. Kurbo's standard specification calls for a 10mm thick and 50mm wide backup bar with rounded edges to protect the flexible element. The bars, in some case, have slotted holes for easy fit up and adjustment

7 Metal Frames or Flanges

Metal frames are used to connect the flexible element to the ductwork. They can be attached directly to the duct work and thus eliminate the necessity for an adjoining duct flange. The flanges establish the stand-off height of the fabric to aid in heat dissipation and passive cooling. It forms a cavity where the insulation pillow can be installed. There are many different types and shapes of frame which can be applied to different application accordingly

8 Metal Liner or Baffle

Kurbo metal liners or baffles are metal shields designed to protect the flexible element and cavity pillow, if present. They also serve to reduce fluttering caused by the air turbulence as it passes over the flexible element. They also can be employed as a heat deflector component of an overall thermal protection system.



BASIC FRAME DESIGN

Kurbo has a variety of frame configurations for fabric expansion joint. Here are Kurbo's basic frame types to best match your application in either "bolt-in" or "weld-in" design

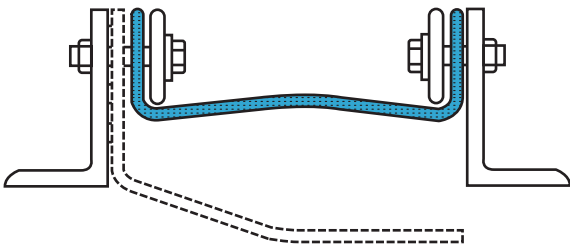

Type IF

- Allows bolting directly to existing duct mating flanges.
- No need for frames in most cases
- Low to moderate temperatures application.
- Primarily used for field installation application.
- Features molded corner in rectangular expansion joint

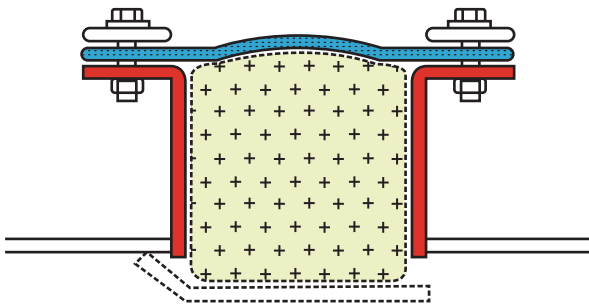

Type AF1

- Economic solution
- Flat belt design for maximum belt life, easy replacement
- Provide stand-off of fabric belt from media
- Made from standard structural angle or fabricated from plate
- Used with or without liners depending on the application

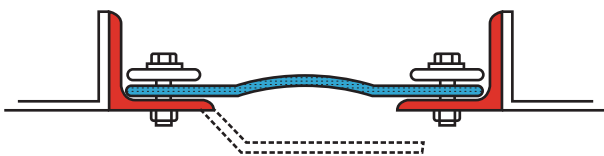

Type AF2

- Economical choice of low profile angle frames
- Normal temperature application
- Fabricated from standard structural profiles or custom bent and/or rolled to suit
- Easy fabric belt replacement
- Flat belt design for maximum belt life, easy replacement
- Reduced field labor costs due to shipment in full assembly
- Supplied with or without liners

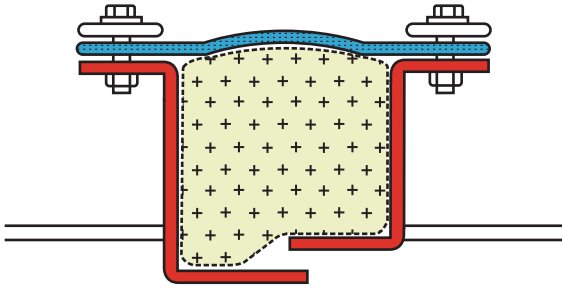

Type ZF

- Easy assembly and installation on site
- Flat belt design for maximum belt life, easy replacement
- Integral telescopic liners offer the best abrasion protection
- No welding is required for liner/baffle installation
- Ideal frame for both high temperature and heavy particulate flow medias.
- Provide stand-off of fabric belt from media
- Large lateral movements
- Superior design for pinning insulation pillows to liners

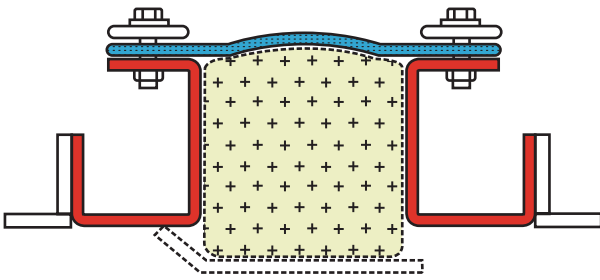

Type JF

- Provide stand-off of fabric belt from media
- High temperature ductwork applications
- Flat belt design for maximum belt life, easy replacement
- Used with either double overlapping or single sided liners.
- Large lateral movements
- Easy fit-up with the fly ash seal.

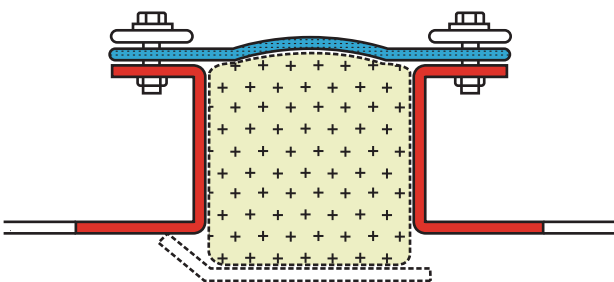

Type CF

- Economical option
- Fabricated with standard structural channel
- Provide stand-off of fabric belt from media
- Flat belt design for maximum belt life, easy replacement
- Provide structural rigidity to the duct opening
- Field welded liner to duct or shop welded liner to frame

Notes

Accumulation pillow and liner can be used depending on the application.

BASIC LINER / BAFFLE DESIGN

Kurbo metal liners or baffles protect the expansion joint's flexible element and insulation/accumulation pillow from fly ash accumulation and abrasion. They will also serve to reduce flutter of the fabric element caused by turbulence and deflect heat. Liners are either an integral part of the expansion joint frame or they can be shipped loose. The many styles of liner which offer different benefits should be discussed when designing an expansion joint. Here are Kurbo's basic baffle or liner styles to best match your application in either "bolt-in" or "weld-in" design

Basic Design of Liner

Straight Style

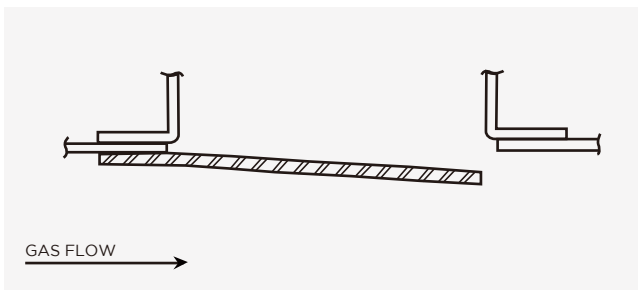

Airfoil Style

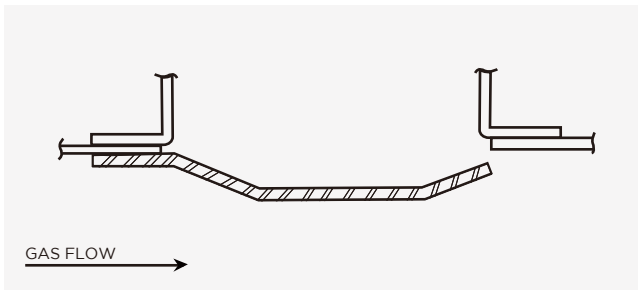

Semi-Airfoil Style

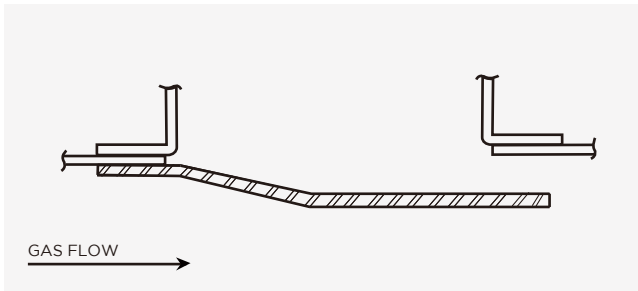

Telescopic Style

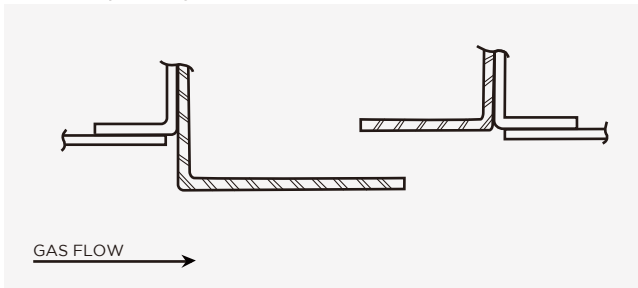

Typical Installations

Shop Welded to Expansion Joint

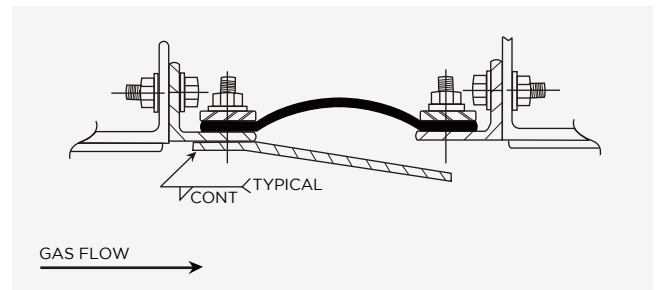

Field Welded to Duct Plate

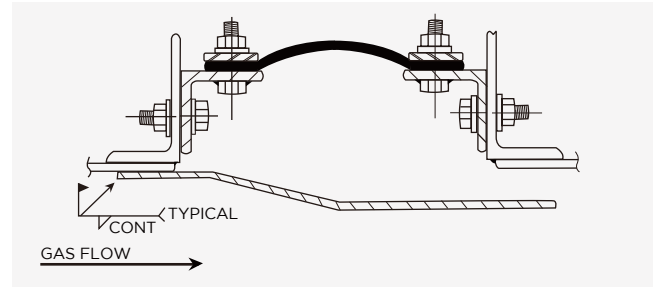

Bolted to Duct Flange

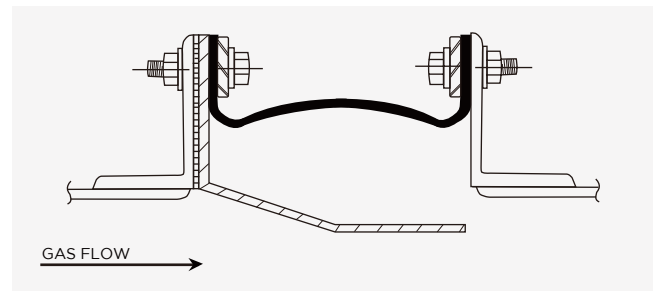

Integral with Expansion Joint Frame

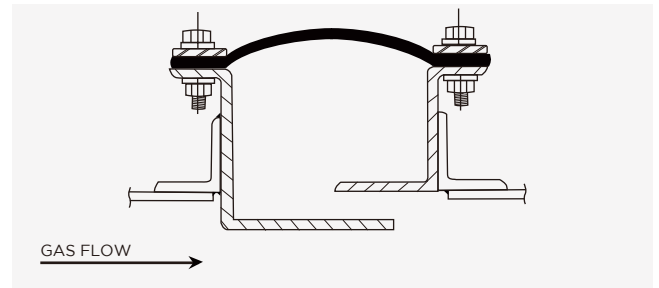

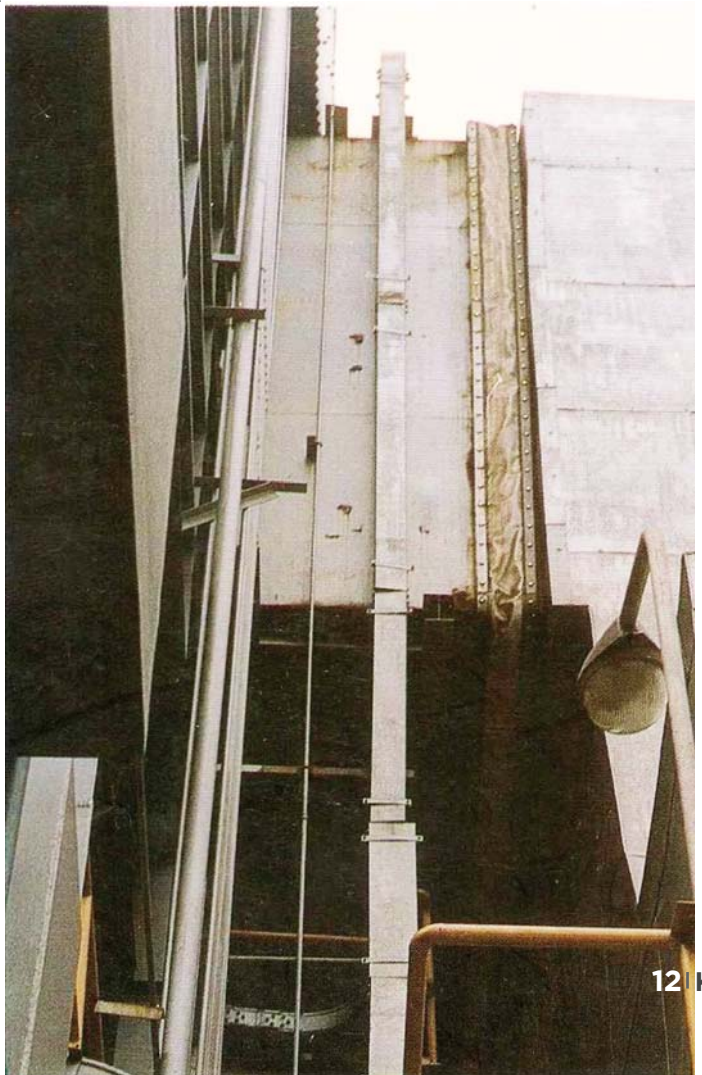

ENGINEERING DESIGN CONCEPT OF KURBO EXPANSION JOINT

Movement Capability

The face-to-face dimension of Kurbo's non-metallic expansion joint, as installed, is a major design consideration. In general, an increased active length results in greater movement capabilities. These dimensional system movements can occur five ways and in any combination. They are outlined below.

Axial Compression: The dimensional shortening of the expansion joint face-to-face gap parallel to its longitudinal axis.

Axial Extension: The dimensional lengthening of the expansion joint face-to-face gap parallel to its longitudinal axis.

Lateral: The dimensional displacement of the inlet and the outlet flanges of the expansion joint perpendicular to its longitudinal axis.

Torsional Rotation: The twisting of one end of the expansion joint with respect to the other end about its longitudinal axis.

Angular Rotation: That movement which occurs when one flange of the expansion joint is moved to an out-of-parallel position



Typical Movement Capability

Belt Type	Active Length	Axial Compression	Axial Extension	Lateral Deflection
Single Layer	6" (150mm)	2" (50mm)	0.5" (13mm)	+/- 1" (25mm)
	9" (230mm)	3" (75mm)	0.5" (13mm)	+/- 1.5" (38mm)
	12" (305mm)	4" (100mm)	1" (25mm)	+/- 2" (50mm)
	16" (406mm)	5" (125mm)	1" (25mm)	+/- 2.5" (63mm)
Composite	6" (150mm)	1" (25mm)	0.5" (13mm)	+/- 0.5" (13mm)
	9" (230mm)	2" (50mm)	0.5" (13mm)	+/- 1" (25mm)
	12" (305mm)	3" (75mm)	1" (25mm)	+/- 1.5" (38mm)
	16" (406mm)	4" (100mm)	1" (25mm)	+/- 2" (50mm)

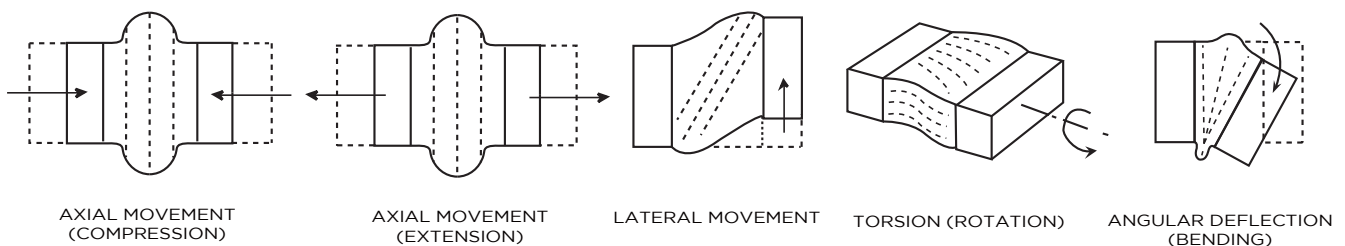

Setback and Flange Height

Setback (Stand-off Height)

Setback is the distance to which the expansion joint (flexible element) is moved outward from the gas stream to allow for lateral movements and to prevent the expansion joint from protruding into the gas stream or rubbing on the baffle when operating under negative pressures.

Proper setback also reduces the thermal transfer effect on the inner face of the expansion joint and prevents abrasion from particles in the gas stream. Consult Kurbo for their recommended setback.

Flange Height

The standard flange height for the integrally flanged type is 75 mm. Variations are available to meet certain applications.

Overall Mating Duct Flange Height

To determine overall mating duct flange heights, expansion joint flange height plus Kurbo's recommended setback must be considered. To accommodate deviations from standard dimensions, custom modifications to standard sizes are available. Consult Kurbo for full details.

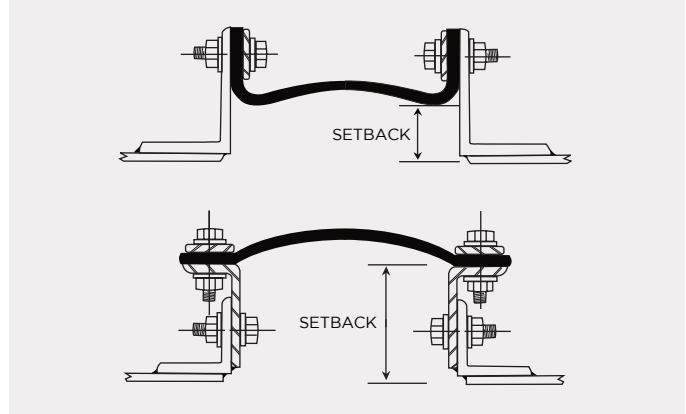

Typical Setback Requirements

Active Length			6" (150mm)	9" (230mm)	12" (305mm)	16" (406mm)
Setback	Flat Belt	Positive Pressure	3" (75mm)	3" (75mm)	4" (100mm)	6" (150mm)
		Negative Pressure	4" (100mm)	6" (150mm)	6" (150mm)	7" (175mm)
	Integral Flange	Positive Pressure	1" (25mm)	1.5" (38mm)	2" (50mm)	2.5" (63mm)
		Negative Pressure	2" (50mm)	3" (75mm)	4" (100mm)	5" (125mm)

Bolt Hole Spacing

Flange bolt hole spacing is standardized at 4 inch (100mm) or 6 inch (150mm) center-to-center distance. This allows for proper sealing of flexible element (expansion joint) at the duct flanges.

Bolt Size	Flange Bolt Hole Spacing
1/2" (M12)	4" (100mm) C-C
5/8" (M16)	4" (100mm) C-C or 6" (150mm) C-C

A "corner hole" is required on all integrally flanged rectangular expansion joints.



Large Duct Misalignment Causes Premature Failure

System Temperature

Insulation and Condensation within the Ducting

High temperature ducting systems are frequently insulated to conserve energy and help prevent internal condensation and corrosion of the ducting. Properly designed expansion joint elements meet these criteria. Poorly designed components will promote problems. The following examples help illustrate correct design methods for expansion joints and ducting insulation.

Insulating Layers

The thermal barrier of a multilayer fabric element must resist heat, moisture and acid attack. Additional retaining layers must be made of materials which remain strong and flexible when exposed to high temperatures and acids or condensates resulting from operation at or below the dew point

When the maximum continuous system operating temperature is near the gas dew point and less than the allowable service temperature of the gas seal membrane material

GOOD DESIGN

Dew Point Composite "Belt Style"

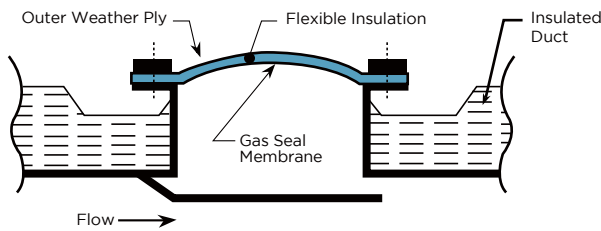

- Expansion joint flexible element is fully insulated to conserve energy, yet easily accessible for inspection and replacement

Single Ply "Belt Style"

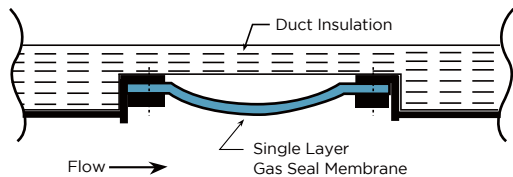

POOR SELECTION OF MATERIALS

Single Ply Gas Seal Membrane

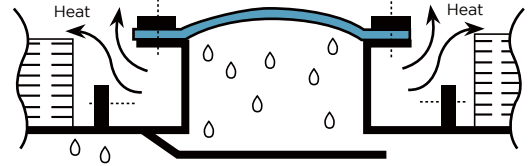

- Ducting and expansion joint are not properly insulated
- Severe condensation is possible
- Costly heat energy is lost

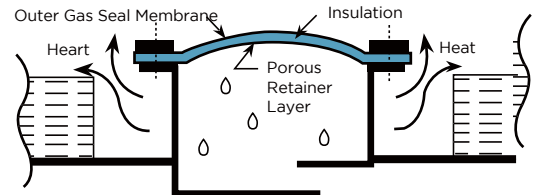

- Misapplication of a "hi-temp" composite belt causes:
- Saturation of insulation by condensates
 - Heat loss
 - Accelerated deterioration of fabric materials

When the maximum continuous system operating temperature exceeds the allowable service temperature of the gas seal membrane material

GOOD DESIGN

High temperature composite belt to 900° F (480° C)

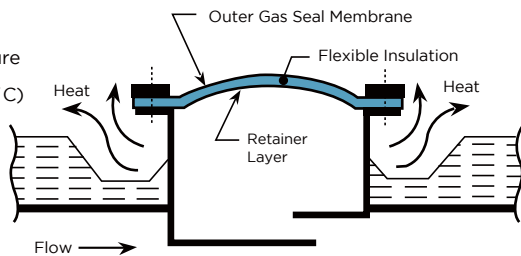

- Minimizes heat loss and permits optimum cooling of the gas seal membrane.
- Flange standoff reduces the temperature of the belt and the critical attachment area, thereby maximizing service life.

Extreme high-temp construction to 1200° F (650° C)

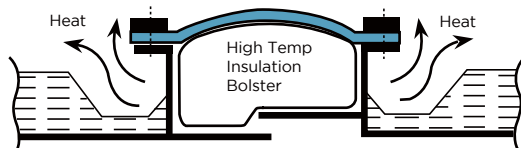

- Additional insulation reduces the temperature in the expansion joint cavity to an acceptable level.

POOR SELECTION OF MATERIALS & CONSTRUCTION

Single Ply Gas Seal Membrane



- Gas seal membrane is exposed to full system temperature
- Attachment flanges are insulated and turned-in, preventing adequate cooling and accelerating deterioration of the gas seal membrane

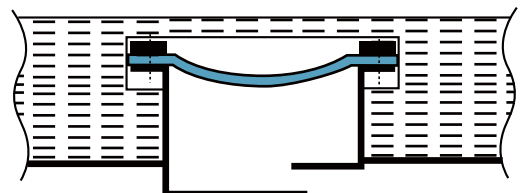

- Exterior insulation prevents the necessary cooling of the gas seal membrane and attachment: flanges, resulting in severe degradation of the expansion joint.

Insulation

When insulating the ductwork care should be taken to properly insulate around the Kurbo fabric expansion joint assembly. Low temperature expansion joints (below 260°C / 500°F) may be insulated over with the concurrence of Kurbo. High temperature expansion joints (over 260°C / 500°F) should not be insulated over. The connection point between the expansion joint element and the mounting frame should allow for adequate cooling

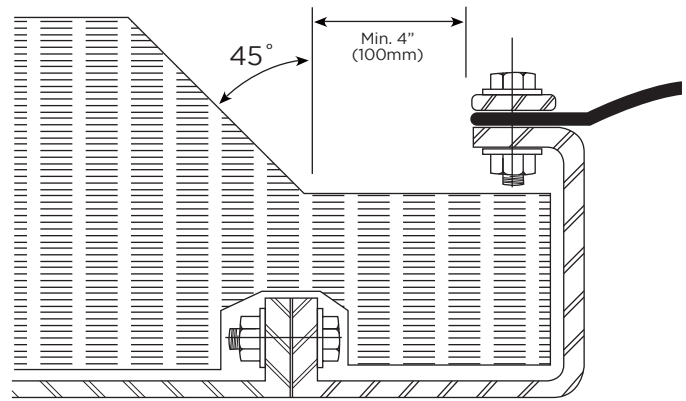

System Pressure

Unlike metal expansion joints, Kurbo's non-metallic(fabric) expansion joints are normally designed for operating pressure from 0.35 barg to -0.35 barg which is in line with the ducting system pressure. Non-metallic expansion joint's low resistance to pressure could lead to premature failure due to pressure variations(pulsation) and flutter. Non-metallic expansion joint with baffle can be an effective solution to help prevent fluttering from occurring.

Prevention of Fly Ash and Abrasive Particulate

Kurbo fabric expansion joints typically create a cavity in the duct-work where fly ash or abrasive particulate can accumulate. The inside surface of the expansion joint must be protected from the direct impingement of particulates. This protection is provided by the metal liner or baffle either welded, bolted or integral to the expansion joint or the duct. When this accumulation becomes severe, it can inhibit movement of the expansion joint. Fly ash accumulation can be minimized by carefully designing liner clearances and adding a fly ash barrier.

These barrier designs include placing insulating materials in the cavity between the expansion joint and the baffle or by installing the elastomeric expansion joint flush with duct inside dimension.

External Environment

Correct operation of Kurbo's high temperature expansion joints requires that a portion of the system heat be dissipated to the external environment. Abnormally hot ambient conditions or an adjacent heat source, reflective surface, or duct insulation may create temperatures which exceed the limits of the gas seal membrane and should be considered when designing the system.

An external cover may be desirable to help protect against falling objects or the accumulation of combustible materials such as coal or saw dust. Covers should be designed to ensure that proper air circulation requirements are satisfied.

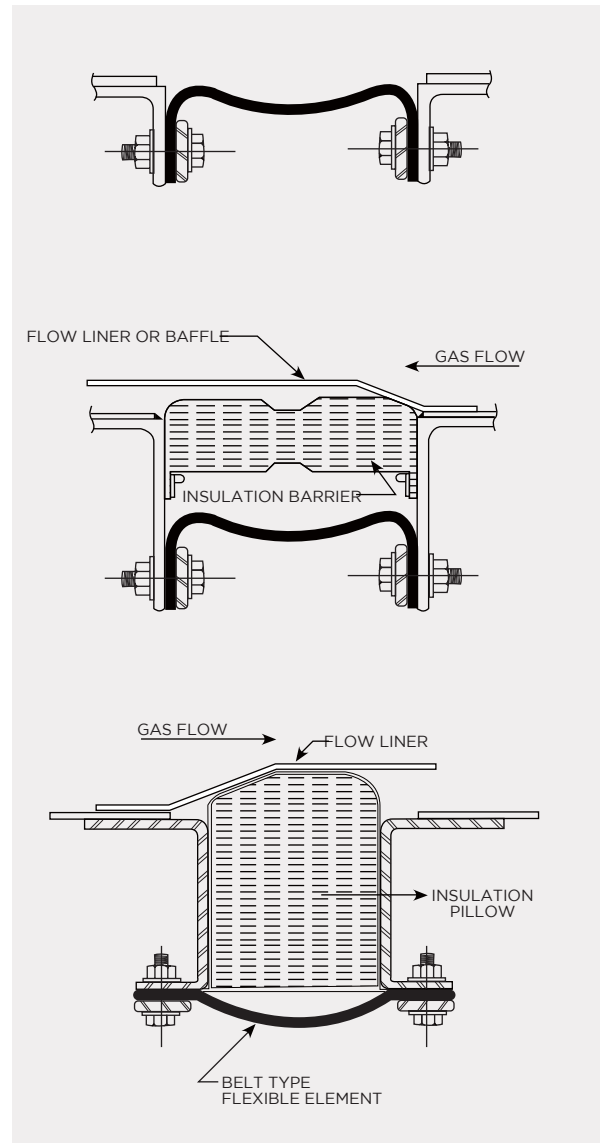

CONSTRUCTION OF KURBO'S TYPICAL FLEXIBLE ELEMENTS

Single Layer Belts

Single layer belts are a combination of reinforcing plies and coatings of elastomers or fluoroplastic which are non-permeable to flue gases and resistant to flue gas acids, chemical, oil and heat. These belts are usually offered in either EPDM, Viton or PTFE varieties

Type SE-150

	<p>A: EPDM, B: Fiberglass, C: EPDM, D: Fiberglass, E: EPDM</p>
<p>Service to 150°C without pillow Service to 500°C with suitable pillow, baffle and frame Pressure up to 0.3 barg Good for dry and wet application</p>	

Type SV-200

	<p>A: FKM (Fluoroelastomer), B: Fiberglass, C: FKM, D: Fiberglass, E: FKM</p>
<p>Service to 200°C without pillow Service to 500°C with suitable pillow, baffle and frame Pressure up to 0.3 barg Good for dry and wet application and high sulfur content exhaust gas</p>	

Type SP-300

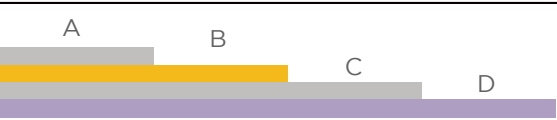
	<p>A: PTFE (Fluoroplastic), B: Fiberglass, C: PTFE, D: PTFE Laminate</p>
<p>Service to 300°C without pillow Service to 500°C with suitable pillow, baffle and frame Pressure up to 0.3 barg Suitable for dry application. In case of wet medium single layer belt with proper frame as an option</p>	

Kurbo modifies and substitutes construction/composition of belting to meet your needs

Composite Belts

Composite belts consist of gas seal membrane, insulation/thermal barrier, retaining and reinforcing plies. These composite belts can be manufactured in either “Flat Belt” or “Integrally Flanged “ varieties



Type CM-400

	A: Outer cover C: Fiberglass cloth E: Fiberglass cloth	B: Gas seal membrane D: Fiberglass mat(12mm)
<p>System temperature to 400°C. Higher operating temperature is available with pillow Pressure up to 0.2 barg Good for dry application</p>		

Type CM-500

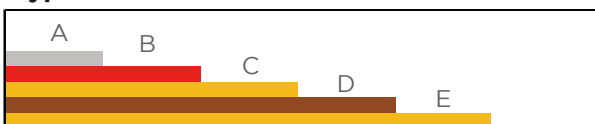
	A: Outer cover C: Fiberglass cloth E: Fiberglass cloth	B: Gas seal membrane D: Fiberglass mat(25mm)
<p>System temperature to 540°C. Pressure up to 0.2 barg Good for dry flue gas and chemical gas application</p>		

Type CM-600

	A: Outer cover C: Fiberglass cloth E: Retaining silica cloth	B: Gas seal membrane D: Fiberglass mat F: SS316 Knitted mesh
<p>System temperature to 540°C. Supplied with pillow Pressure up to 0.2 barg Excellent mechanical stability Good for dry flue gas and chemical gas application</p>		

Type CM-1000

	A: Outer cover C: Fiberglass cloth E: Retaining silica cloth	B: Gas seal membrane D: Fiberglass mat F: SS316 Knitted mesh
<p>System temperature to 1000°C. Supplied with pillow and refractory Pressure up to 0.2 barg Excellent mechanical stability Good for dry flue gas and chemical gas application</p>		

Construction/composition of belting can be modified or substituted to meet your needs.

Kurbo Fabric Expansion Joint Specification Sheet

YOUR CUSTOMER

Date _____ Page _____ of _____

Project Name _____

Delivery Required _____

Item / Tag No. _____ Item / Tag No. _____ Item / Tag No. _____

Q'ty Required _____ Q'ty Required _____ Q'ty Required _____

YOUR COMPANY

Company Name _____

Mailing Address _____

Name of Person _____ Email _____

SIZE	Duct Size (inside dimension or diameter)	_____ mm	_____ mm	_____ mm
	Face to Face Dimension (in replacement or requirement)	_____ mm	_____ mm	_____ mm
SERVICE/GAS	Location of EJ (nearest equipment, inlet/outlet)	_____	_____	_____
	Flowing Medium (air, fluegas, gas, dust etc)	_____	_____	_____
	Dust Load	_____ kg/m ²	_____ kg/m ²	_____ kg/m ²
	Flow Velocity	_____ m/sec	_____ m/sec	_____ m/sec
	Flow Direction (up, down, horizontal, angular up, angular down)	_____	_____	_____
PRESS	Design Pressure (bar or mAq)	_____ bar	_____ bar	_____ bar
	Operating Pressure (bar or mAq)	_____ bar	_____ bar	_____ bar
TEMP	Operating Temperature	_____ °C	_____ °C	_____ °C
	Excursion Temperature / Duration	_____ °C / Hr	_____ °C / Hr	_____ °C / Hr
	Ambient Temperature Maximum / Minimum	_____ / °C	_____ / °C	_____ / °C
MOVEMENT	Axial Compression	_____ mm	_____ mm	_____ mm
	Axial Extension	_____ mm	_____ mm	_____ mm
	Lateral Deflection Parallel to Long Side "Y"	_____ mm	_____ mm	_____ mm
	Lateral Deflection Parallel to Short Side "Z"	_____ mm	_____ mm	_____ mm
	Angular / Torsional Movement (degree)	_____ /	_____ /	_____ /
DUCT	Duct Material	_____	_____	_____
	Duct Inside Dimensions / Thickness(mm)	_____ /	_____ /	_____ /
	Duct Corner (radius or square)	_____	_____	_____
	Duct or Fly Ash Barrier (yes or no)	_____	_____	_____
	Internal Liner	_____	_____	_____

Frame and Belt Type Selection (Custom design or others available: Please provide sketch)

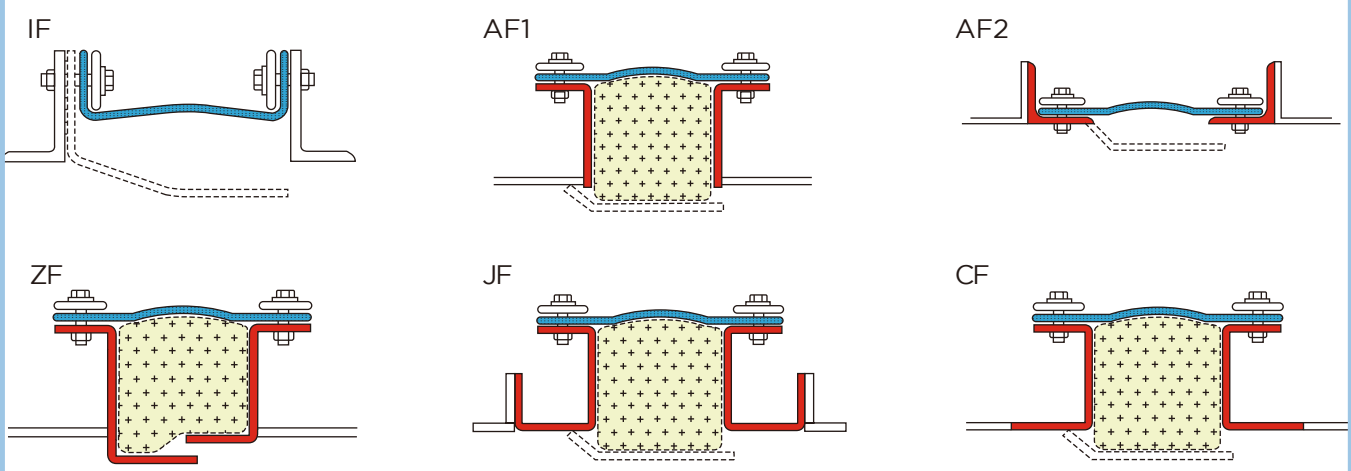

COMMENTS

Complete Line of Kurbo Expansion Joints

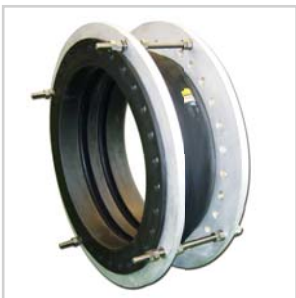

Rubber Expansion Joint



Metal Expansion Joint



Fabric Expansion Joint



PTFE Lined Expansion Joint



PTFE Expansion Joint



Flexible Joint



Flexible Metal Hose

winflex



**Specialist of Rubber Expansion Joint, Metal Expansion Joint,
Fabric Expansion Joint, PTFE Expansion Joint, Flexible Metal Hose
and other flexible products**

**Kurbo Company Limited
1504-8 Songjeong-dong, Gangseo-gu, Busan 618-817, Korea
Tel +82-51-831 1291 / Fax +82-51-831 1295
www.kurbo.co.kr www.winflex.co.kr Email: kurbo@kurbo.co.kr**