



# Rubber Expansion Joints and Flexible Pipe Connector

---



# KURBO WinFlex



## C O N T E N T S

<b>Introduction to Kurbo</b>	.....	<b>2</b>
<b>Product Information</b>	.....	<b>6</b>
<b>Rubber Expansion Joint</b>		
Series 20W Wide arch type expansion joint	.....	<b>8</b>
Type 21W-24W, F21W	.....	<b>10</b>
Series 10 Spool arch type expansion joint	.....	<b>18</b>
Series 20UG Underground expansion joint	.....	<b>20</b>
Type 21UG-24UG	.....	<b>22</b>
Type 22GB-3, 22GB-4, 23UG-PL, 24UG-PL	.....	<b>26</b>
Type 21EP Externally pressurized joint	.....	<b>28</b>
Type 21DM Demounting joint		<b>30</b>
Type 21FL Flowing arch type joint	.....	<b>32</b>
Type 21M Molded wide arch type joint	.....	<b>34</b>
Type 21TL PTFE lined joint	.....	<b>35</b>
Type 21CR, 21ER Concentric and Eccentric reducer	.....	<b>36</b>
Control Units with Rubber flanged expansion joint	.....	<b>38</b>
Type 31FF, 32FF Floating flange design	.....	<b>40</b>
Type 31BF, 32BF Built-in flange design	.....	<b>41</b>
Series 30UG Underground joint with floating flange	.....	<b>42</b>
Type 31UG-34UG	.....	<b>44</b>
Series 30M Molded sphere expansion joint	.....	<b>46</b>
Control Units with Steel flange type expansion joint	.....	<b>48</b>
Series 50 Sleeve type expansion joint	.....	<b>50</b>
<b>Pipe Connector and Duct Connector</b>		
Type 60 Pipe/Pump connector	.....	<b>52</b>
Type 60E Elbow connector	.....	<b>54</b>
Type 70U U-Design duct connector	.....	<b>56</b>
Type 70V Arch-Design duct connector	.....	<b>57</b>
Type 70W W-Design duct connector	.....	<b>58</b>
Type 80 Flexible hose connector		<b>59</b>
<b>Pipe Penetration Seal</b>		
Type 90A, 90B Arch or Bag Type	.....	<b>60</b>
<b>PTFE Expansion Joint</b>		
Type 133, 135 Three and five convolution	.....	<b>62</b>
<b>Other Specialty Products</b>		
Pressure balanced type, retrofit type, gimbal type etc	.....	<b>63</b>
<b>Labelling System</b>	.....	<b>64</b>
<b>Dimension Inspection</b>	.....	<b>65</b>
<b>Installation and Maintenance Guide</b>	.....	<b>66</b>
<b>Kurbo Expansion Joints Installed in Different System</b>	.....	<b>70</b>
<b>Design, Manufacturing and Testing Capability</b>	.....	<b>72</b>
<b>Technical Information and Reference Data</b>	.....	<b>79</b>
General characteristic and property of elastomers	.....	<b>80</b>
Flange drilling data	.....	<b>82</b>
Unit conversion	.....	<b>86</b>
Expansion joint specification sheet	.....	<b>88</b>

# Introduction to Kurbo

Since our foundation in 1996, we have focused on providing our customers with high levels of quality products and services suited for individual piping system requirements. We are striving to be an integrated manufacturer and specialist in the field of elastomeric expansion joints. Taking one step forward, continuous efforts are being focused on developing improved and new products to be highlighted as a substitute of conventional products.

With a full range of manufacturing, engineering and testing capabilities, Kurbo can provide its customers with the assurance that its products will meet their needs. All aspects of production are quality-assured with the plant being accredited to ISO 9001 and the Pressure Equipment Directive (PED) with audits by TUV. We monitor and control every aspect of manufacturing process, from compound development to the finished products.

Over the years, Kurbo has had extensive experience in piping industry and detailed knowledge of rubber processing, broad selection of elastomers. With these tried and time-tested ways, we have been offering total solutions to piping problems.

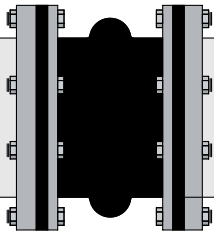

*For the Best Piping Solution*

Extending our sincere gratitude to all parties interested in us, let alone our customers, We pledge to devote ourselves to solve our customer's application problems and development of piping industry.

Imsoo Park / President



**Welcome  
to  
Kurbo**

## History

- 1996.** Established Kurbo Industrial Company as a manufacturer of rubber expansion joints and flexible connectors
- 1997.** For marine service, developed flame resistant rubber expansion joint in accordance with 30 CFR 18.65 which meets MIL-E-15330D Navy spec. and U.S Coast Guard requirements
- 1998.** Acquired ISO 9002 quality certificate
- 1999.** For food service, developed Food Grade Neoprene rubber and passed FDA extraction test Approved by Doosan Heavy
- 1999.** Approved by Doosan Heavy Industries and Construction Co., Ltd. (Hanjung)
- 2000.** Incorporated as Kurbo Co., Ltd.
- 2000.** Completed new head office and factory and moved to the present location and equipped most modernized facilities
- 2001.** Acquired ISO 9001:2000 quality certificate from Korean Foundation for Quality (KFQ)
- 2001.** Approved by Korea Electric Power Corporation (KEPCO)
- 2001.** Awarded "One Million Dollar Export Award"
- 2002.** Developed earthquake-proof expansion joint for direct burial application
- 2004.** Acquired CE Mark (PED QA System)
- 2005.** Completed construction of 2nd plant for R&D and testing
- 2007.** Awarded "Three Million Dollar Export Award"
- 2008.** Selected as a promising small and medium company
- 2009.** Developed Food Grade white EPDM compounds in accordance with 21 CFR 177.2600 which meet the requirements of FDA list of Substances and Limitations
- 2010.** Selected as a venture company by Korea Technology Finance Corp.
- 2011.** Selected as an INNO-BIZ company by Small and Medium Business Admi.
- 2011.** Obtained patent for "Expansion joint for pipe and manufacturing method"
- 2011.** Approved by Korea Electric Power Corporation((KEPCQ)
- 2012.** Approved by Hyundai Construction and Engineering
- 2012.** Approved by Toshiba Plant Systems & Services Corporation
- 2012.** Approved by Hitachi Zosen Corporation

## Profile

<b>Name</b>	Kurbo Company Limited
<b>President</b>	Imsoo Park
<b>Head Office &amp; Factory</b>	1504-8, Songjeong-dong, Gangseo-gu, Busan 618-817, Korea
	Tel. +82-51-831 1291 Fax +82-51-831 1295
	E-Mail : kurbo@kurbo.co.kr
<b>Established</b>	January 1996
<b>Business Area</b>	Design, development, production and sales of various types of rubber expansion joints and flexible pipe/duct connectors for industrial piping/ducting systems. And other industrial rubber products including elastomeric sleeves for pinch valve, dredging hose, rubber riser etc.
<b>Main Products</b>	Expansion joint and flexible connector
<b>Land Area</b>	3600 Square Meters
<b>Building Area</b>	2800 Square Meters

## Organization

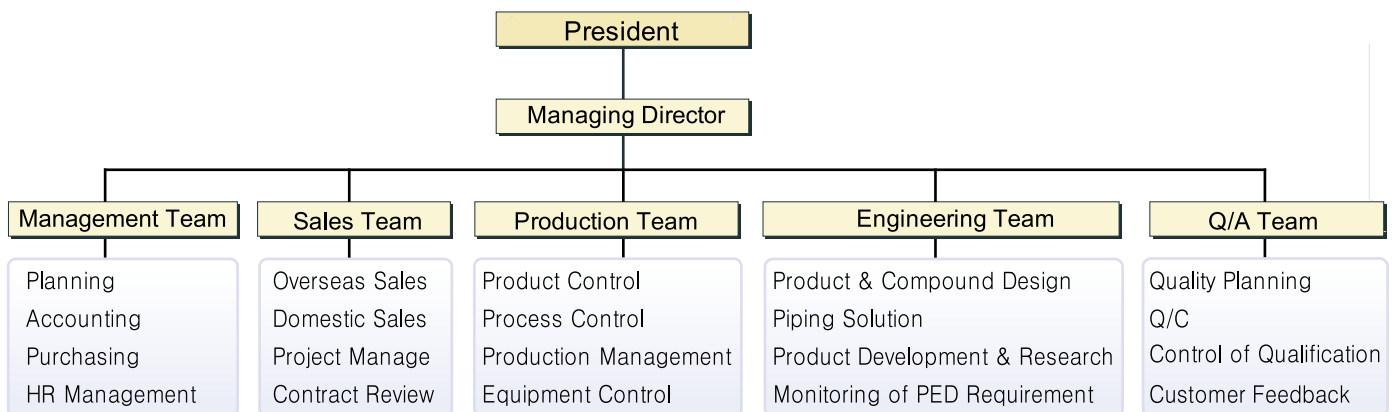

## ■ Quality Management System

It is Kurbo policy to maintain and implement the quality management system which is structured upon the ISO 9001 : 2000 standards, the requirements of PED and contractual specification and meet the needs and expectations of customers and guarantee complete customer satisfaction.

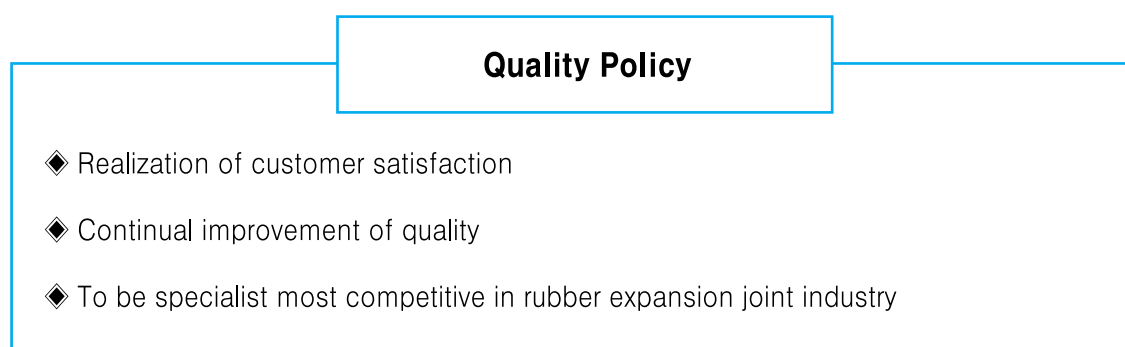

To achieve these quality policy, Kurbo establishes and implements the quality objectives as follows.

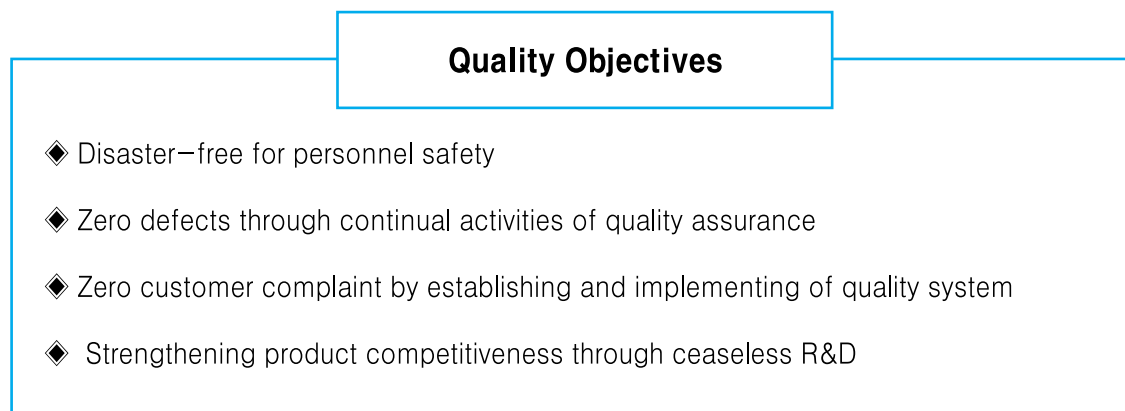

Customer satisfaction is a fundamental objective of Kurbo. All employees in Kurbo continuously improve its processes and services until the customer's needs have all been satisfied.

Quality management is the key to higher productivity and cost savings and the obligation of every single employee in Kurbo. Therefore all members of Kurbo devote themselves to fulfill quality management in line with KSA / ISO 9001 standard and Kurbo's quality management directives

## Product Information

Kurbo Winflex Rubber Expansion Joints are used to provide relief from stresses caused by thermal movement and mechanical activity in piping and ducting systems. The other main job is to reduce noise, isolate vibration, compensate for misalignment and prolong the life of motive equipment. They also provide excellent resistance to shock and wear.

Kurbo offers a wide variety of designs to meet various piping system requirements such as different pressure, temperature, movement, stiffness, fluid resistance, end connection with mating pipe flange etc.



### Expansion Joint Types

Kurbo Winflex joints are available in a broad range of joint types for virtually processing in your most demanding applications: Standard spool arch, wide arch, flowing spherical arch type, tapered reducer type, offset type, sleeve type, pipe connector, elbow, tee, lateral, cross, U-type in round, oval, rectangular shape. Modifications to filled arch, multiple arch are also available.

As a specialty, submerged (externally pressurized) type, pressure balanced type, underground type, gimbal, universal type, retrofit joint are also available.

### Sizes

Various range of Winflex joints in size from DN20 to DN3600.



### Elastomer Grades

Winflex joint elastomers range from natural rubber to fluoroelastomer. Fluoroplastic for liner is available. You can choose tube and cover materials to suit media, temperature, chemical and environmental conditions. Our "Chemical Resistance Guide" will give you information on elastomer/chemical compatibility for piping processes.

### Reinforcing Materials

Various fabric and metal reinforcements are available. Depending upon temperature ratings, nylon, polyester, Polyaramid are used. To increase pressure /vacuum capability, spring steel wire and solid annular rings are used.





### Pressure Ratings

Kurbo offers Winflex joints for extremely high pressure applications up to 50 bars. The heavy-duty design exceed 4:1 safety factor. This is proven through our recent 3 years' burst test program.

### Wide Temperature Range

Winflex joint can operate efficiently from  $-20^{\circ}\text{C}$  to  $120^{\circ}\text{C}$   
Contact Kurbo for applications in other temperature ranges.

### Greater Movement Capability

Wide and large arch profile and fabric angle adjustment provides great flexibility and increased all directional movement capability.

### Lower Movement Forces

Unique arch design of Winflex joint combined with radial tire cord construction provides lower flange forces—less stress in piping system.

### Superior Reliability and Durability—Extended Service Life

Our technical expertise, professional workmanship and years of experience coupled with detailed knowledge of elastomers, their characteristics and applications allow Kurbo Winflex joints to guarantee longer service life. Research and development are not options. They are integral part of our business.

*Available elastomers, materials, sizes and options vary between expansion joint types.*





## Series 20W Wide Arch Type Expansion Joint

Kurbo Series 20W, wide arch type expansion joints are reengineered design to improve movement and spring rate capabilities of Kurbo Series 10 conventional spool arch type expansion joints.

Utilizing modern engineering principles and materials developed in tire industry, we create the Series 20W, new and improved design that provides great movement capability, lower spring rate with no sacrifice of strength.

As seen in the tables on page 10 and 19, the movement capability of Type 21W, single wide arch expansion joint is greater than or equal to that of Type 12 double spool arch joint, while offering shorter face to face length. The Type 22W, double wide arch expansion joints provide about 40% higher axial movement capability and 30% greater lateral movement capability than the Type 13, triple spool arch products, maintaining shorter or the same face to face length. Thus, they eliminate the needs for double or multiple arch spool type joints resulting in less cost.

*Now, Kurbo Series 10 conventional designs are available only in short face to face length and for replacement purpose. See the engineering table on page 19 for the Series 10's dimension, movement, spring rate and pressure ratings.*

### Typical Construction of 20W

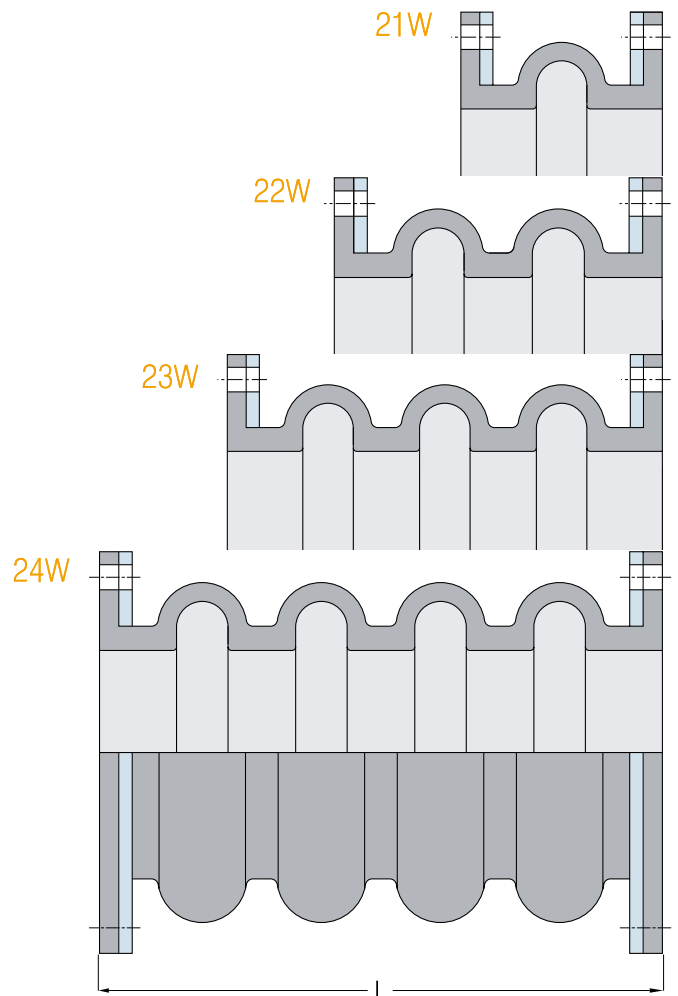
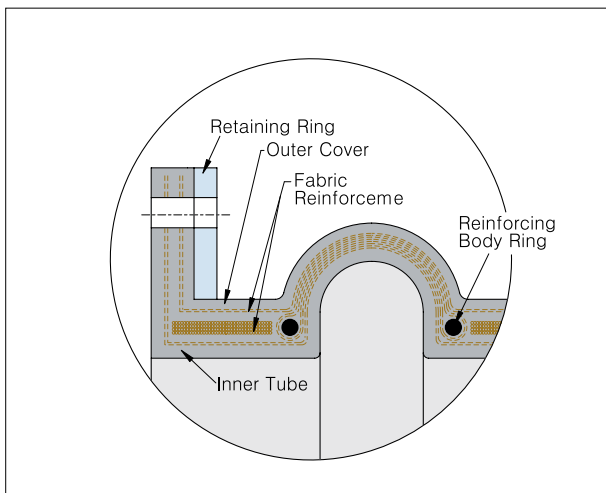
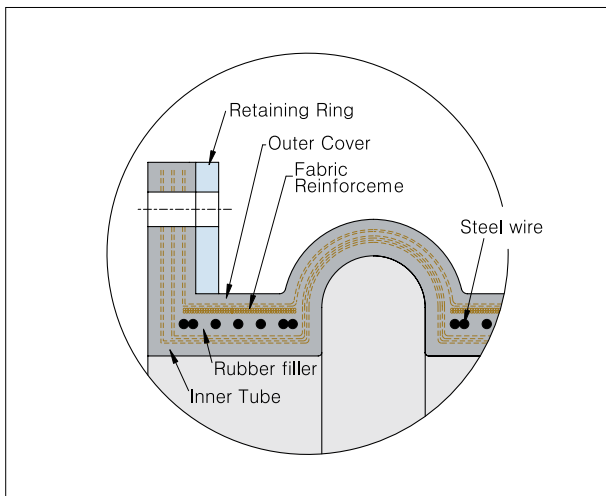

## Features

- **Greater movement** : More than 2 times greater movement capability than conventional product, while offering the same face to face length.
- **Greater flexibility** : Wide arch profile and fabric angle adjustment provides great flexibility and increased all directional movement capability.
- **Lower spring rates** : Wide and large arch profile coupled with radial tire cord construction allows the 20W to provide lower flange forces—less stress in piping system. Kurbo has completed flex test for sizes up to DN1200 and currently testing larger sizes.
- **Greater strength and higher pressure rating** : Unique arrangement of spring steel wire and combined construction of bias/radial tire cord increases pressure/vacuum capability : All 21W up to DN1800 are designed to withstand full vacuum rating.
- **Greater than 4 to 1 safety factor** : Series 20W are fully tested in factory and also proven through the industry.
- **Higher temperature rating** : Standard materials of the 20W are EPDM tube/cover and polyester tire cord, so recommended to 120°C. 200°C continuous service available.
- **Superior reliability and durability—Extended service life** : With quality materials and optimum selection of construction and professional workmanship allow Kurbo 20W to guarantee longer service life.
- **Wide variety of elastomers** : As a standard elastomers, choice of natural, neoprene, nitrile, SBR, butyl, EPDM, Hypalon elastomers are available. As a special, food grade white rubber, flame resistance rubber, Viton, Teflon and more available. Please refer to Kurbo "Chemical Resistance Guide" for recommendations on elastomer best suited for the chemical/process fluid in your system.
- **Wide spectrum of fabric and metal reinforcements** : Standard fabric is high tensile polyester tire cord. Other materials like nylon, Kevlar, Nomex available. Various corrosion resistant steel wire and annular ring are used in carcass for pressure/vacuum bearing reinforcement layers.
- **Cover coating** : For extra U.V. protection, the 20W are hypalon(CSM) coated .
- **Less cost** : No need for traditional product with double arch— Less project cost
- **Lighter weight** : Less transportation and installation cost
- **Flanged design** : No gasket required due to seamless rubber flange face.
- **No ring spacer required** : Available with recessed rubber flange face for raised face flange connections.

Kurbo Series 20W Available Material and Operating Temperature				
Material Code	Elastomer		Maximum	
	Outer Cover	Inner Tube	Operating Temperature	
BB	Butyl	Butyl	120°C	250°F
NN	Neoprene	Neoprene	100°C	210°F
EE	EPDM	EPDM	120°C	250°F
HH	Hypalon-CSM	Hypalon-CSM	110°C	230°F
NH	Neoprene	Hypalon-CSM	110°C	230°F
NP	Neoprene	Nitrile	90°C	200°F
NQ	Neoprene	HNBR	150°C	300°F
NR	Neoprene	Natural	80°C	180°F
NV	Neoprene	Viton	200°C	400°F
NT	Neoprene	Teflon	200°C	400°F
NF	Neoprene	Food grade Neoprene	100°C	210°F
EF	EPDM	Food grade EPDM	120°C	250°F

## Type 21W One Open Wide Arch

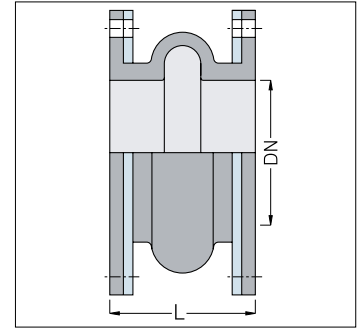

### Movement · Spring Rate · Pressure Rating

Nominal Size		Min. Length		Movement Capability				Spring Rates			Max. Pressure (bar)	Vacuum Rating (mmHg)
DN	inch	mm	inch	Comp. (mm)	Ext. (mm)	Lat. (mm)	Ang. (deg.)	Comp. (kg/mm)	Ext. (kg/mm)	Lat. (kg/mm)		
25	1	150	6	20	10	12	38.2	2.4	3.5	4.3	12	760
32	1.25	150	6	20	10	12	32.2	2.4	3.5	4.4	12	760
40	1.5	150	6	20	10	12	27.7	2.7	3.9	4.8	12	760
50	2	150	6	35	17	16	34.6	2.9	4.3	5.3	12	760
65	2.5	150	6	35	17	16	28.9	3.4	4.9	6.1	12	760
80	3	150	6	35	17	16	24.7	3.8	5.5	6.9	12	760
100	4	150	6	35	17	16	19.0	4.4	6.3	7.8	12	760
125	5	150	6	40	20	18	17.5	5.1	7.4	9.2	12	760
150	6	150	6	40	20	18	14.7	6.8	9.9	12.6	12	760
200	8	150	6	40	20	18	11.1	8.6	12.4	15.9	10	760
250	10	200	8	40	20	18	8.9	10.3	15.0	19.1	10	760
300	12	200	8	40	20	20	7.5	13.3	19.4	25.4	10	760
350	14	200	8	40	20	20	6.4	15.2	22.1	29.0	10	760
400	16	200	8	40	20	20	5.6	17.1	24.9	32.6	8	760
450	18	200	8	40	20	20	5.0	19.0	27.6	36.2	8	760
500	20	200	8	40	20	20	4.5	20.9	30.4	39.8	8	760
550	22	250	10	50	25	23	5.1	24.6	35.7	49.2	8	760
600	24	250	10	50	25	23	4.7	26.6	38.6	53.3	8	760
650	26	250	10	50	25	23	4.3	28.7	41.6	57.3	7	760
700	28	250	10	50	25	23	4.0	30.7	44.5	61.4	7	760
750	30	250	10	50	25	23	3.8	32.7	47.4	65.4	7	760
800	32	250	10	50	25	23	3.5	34.7	50.4	69.5	7	760
850	34	250	10	50	25	23	3.3	36.8	53.3	73.5	7	760
900	36	250	10	50	25	23	3.1	38.8	56.2	77.6	7	760
950	38	250	10	50	25	23	3.0	40.8	59.2	81.6	7	760
1000	40	250	10	50	25	23	2.8	42.8	62.1	85.7	7	760
1050	42	300	12	60	30	25	3.2	44.9	65.1	89.7	6	760
1100	44	300	12	60	30	25	3.1	46.9	68.0	93.8	6	760
1150	46	300	12	60	30	25	2.9	42.6	61.7	93.7	6	760
1200	48	300	12	60	30	25	2.8	44.3	64.3	97.5	6	760
1250	50	300	12	60	30	25	2.7	46.1	66.8	101.4	6	760
1300	52	300	12	60	30	25	2.6	47.8	69.3	105.2	6	760
1350	54	300	12	60	30	25	2.5	49.6	71.9	109.1	6	760
1400	56	300	12	60	30	25	2.4	51.3	74.4	112.9	6	760
1450	58	300	12	60	30	25	2.3	53.1	76.9	116.7	6	760
1500	60	300	12	60	30	25	2.3	54.8	79.5	120.6	6	760
1650	66	300	12	60	30	25	2.0	60.1	87.1	132.1	6	760
1800	72	300	12	60	30	25	1.9	65.3	94.7	143.7	5	760
1950	78	300	12	60	30	25	1.7	76.9	111.5	169.2	5	700
2100	84	300	12	60	30	25	1.6	85.8	124.3	188.7	5	700
2250	90	300	12	60	30	25	1.5	91.7	132.9	201.7	4	700
2400	96	300	12	60	30	25	1.4	97.6	141.5	214.7	4	700
2550	102	300	12	60	30	25	1.3	106.8	154.8	234.9	4	700
2700	108	300	12	60	30	25	1.3	112.9	163.6	248.3	4	700
3000	120	300	12	60	30	25	1.1	125.0	181.3	275.1	3	700
3300	132	300	12	60	30	25	1.0	137.2	198.9	301.8	3	700
3600	144	300	12	60	30	25	0.9	149.4	216.6	328.6	3	700

1. Spring rates are based on single open arch at zero pressure conditions. They should be considered as approximates which may vary with elastomers and fabrics used in fabrication and specific construction design.
2. Contact Kurbo for spring rates of multiple and filled arch products.
3. The expansion joints can be manufactured in different lengths.

### Different Types of Movements that the 20W Absorb...

Rubber expansion joints are capable of axial compression, axial extension, lateral and angular movement. In many cases, these movements are all taking place at a time. Winflex 20W are designed to absorb different movements concurrently. Other main job is to reduce noise and vibration by creating a discontinuity between piping materials.

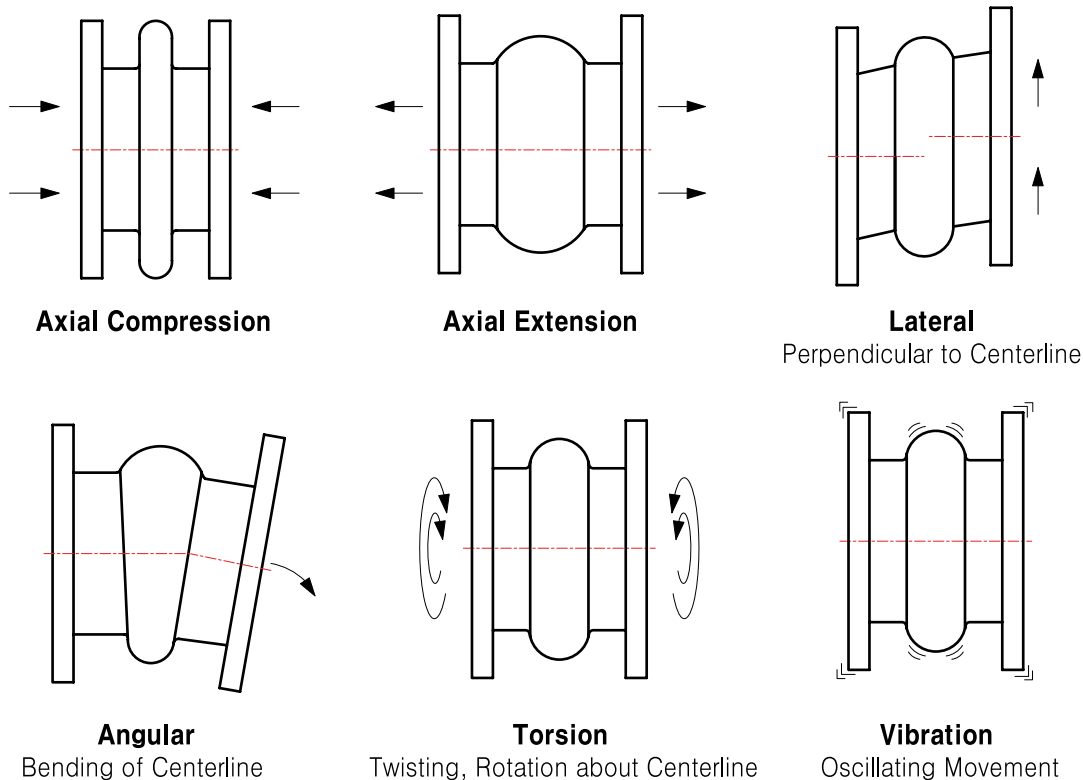

### Spring Rate Curve of 21W

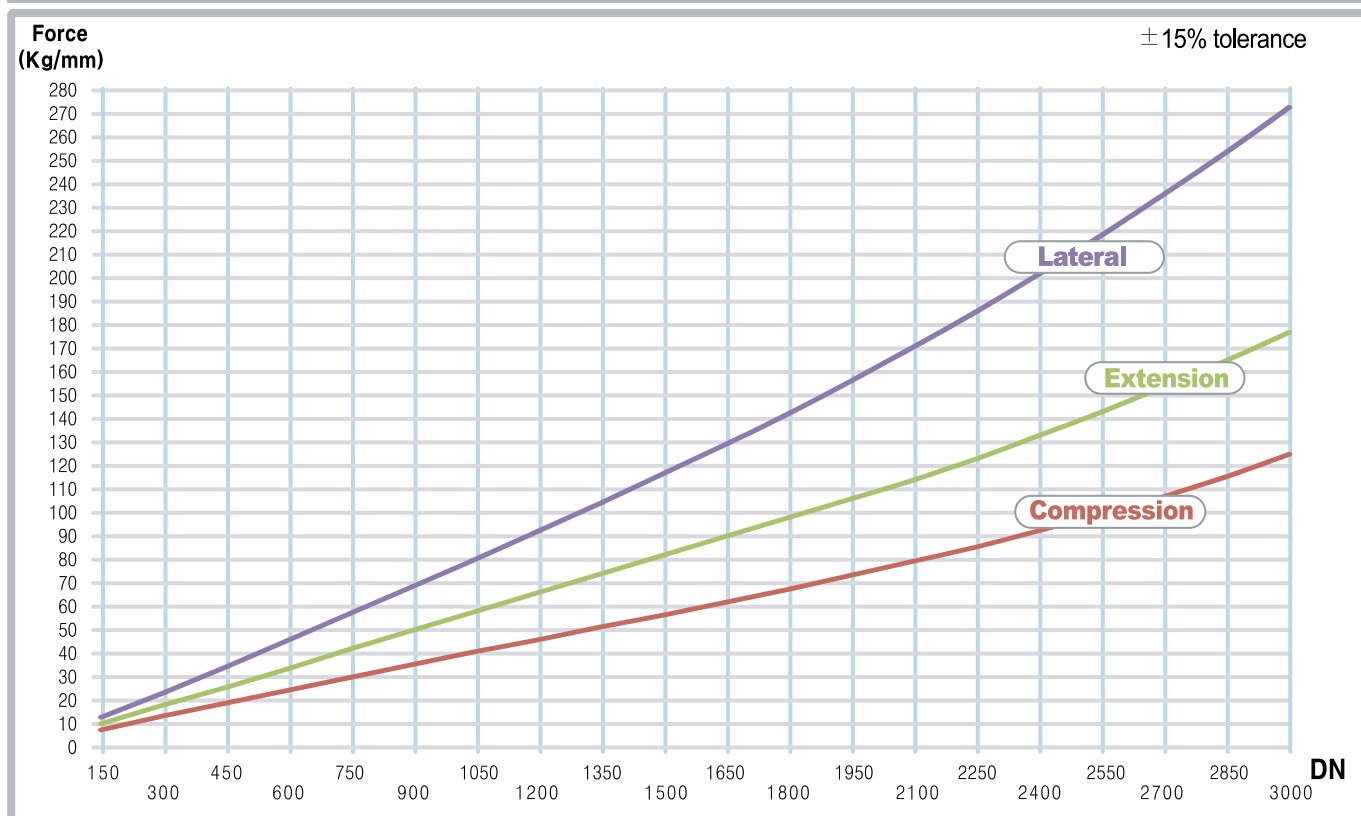

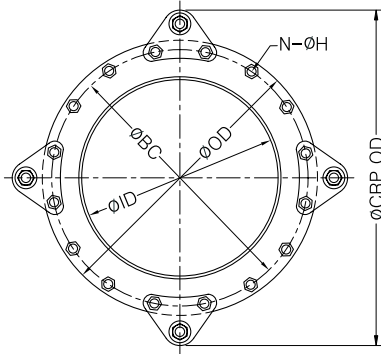
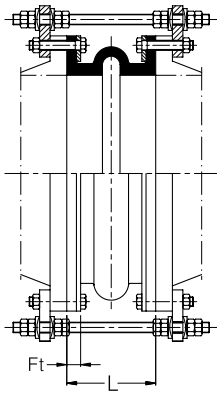

## Dimension and Weight - ANSI 150 lbs Drill

Nominal Size		Min. Length		Dimensions - ANSI 150 lbs							Weights (kg)		
DN	inch	mm	inch	Ft (mm)	I.D (mm)	O.D. (mm)	B.C. (mm)	No. of Holes(N)	Hole Dia. (øH)	CRP O.D.	Exp Joint	Retaining Ring Set	Control Rod Set(1)
25	1	150	6	22	25	108	79.4	4	16	184	0.6	0.8	1.2
32	1.25	150	6	22	32	118	88.9	4	16	195	0.7	1.0	1.3
40	1.5	150	6	22	38	127	98.4	4	16	203	0.8	1.1	1.3
50	2	150	6	22	51	152	120.7	4	19	241	1.1	1.6	2.2
65	2.5	150	6	22	64	178	139.7	4	19	269	1.5	2.2	2.4
80	3	150	6	22	76	191	152.4	4	19	279	1.7	2.3	2.5
100	4	150	6	22	102	229	190.5	8	19	318	2.3	3.3	2.0
125	5	150	6	24	127	254	215.9	8	22	343	3.0	3.5	2.2
150	6	150	6	24	152	279	241.3	8	22	369	3.5	3.9	2.6
200	8	150	6	27	203	343	298.5	8	22	447	5.2	5.9	3.8
250	10	200	8	27	254	406	362.0	12	25	518	8.1	7.8	5.5
300	12	200	8	27	305	483	431.8	12	25	607	11.3	11.4	6.9
350	14	200	8	30	356	533	476.3	12	29	658	13.8	12.7	7.6
400	16	200	8	30	406	597	539.8	16	29	734	16.1	16.0	8.5
450	18	200	8	30	457	635	577.9	16	32	771	16.3	14.7	9.0
500	20	200	8	33	508	699	635.0	20	32	835	19.5	17.9	8.7
550	22	250	10	33	559	749	692.2	20	35	897	25.2	18.3	12.9
600	24	250	10	33	610	813	749.3	20	35	962	28.7	21.5	13.4
650	26	250	10	33	660	870	806.5	24	35	1017	32.7	23.6	13.1
700	28	250	10	33	711	927	863.6	28	35	1085	35.4	25.9	16.4
750	30	250	10	33	762	984	914.4	28	35	1154	38.4	29.4	19.2
800	32	250	10	33	813	1060	977.9	28	41	1230	42.7	37.5	20.9
850	34	250	10	33	864	1111	1028.7	32	41	1292	45.7	37.8	24.0
900	36	250	10	33	914	1168	1085.9	32	41	1363	49.0	40.2	25.9
950	38	250	10	33	965	1238	1149.4	32	41	1431	53.8	50.0	26.5
1000	40	250	10	33	1016	1289	1200.2	36	41	1459	56.3	50.9	23.4
1050	42	300	12	38	1067	1346	1257.3	36	41	1528	76.6	52.6	25.6
1100	44	300	12	38	1118	1403	1314.5	40	41	1586	80.8	56.3	25.3
1150	46	300	12	38	1168	1454	1365.3	40	41	1637	85.4	57.9	25.6
1200	48	300	12	38	1219	1511	1422.4	44	41	1704	89.6	63.1	28.5
1250	50	300	12	38	1270	1568	1479.6	44	48	1762	92.9	63.3	30.3
1300	52	300	12	38	1321	1626	1536.7	44	48	1819	97.8	70.1	30.7
1350	54	300	12	38	1372	1683	1593.9	44	51	1904	106.5	73.8	39.8
1400	56	300	12	38	1422	1746	1651.0	48	48	1965	112.9	80.4	38.9
1450	58	300	12	38	1473	1803	1708.2	48	48	2022	118.0	86.7	39.4
1500	60	300	12	38	1524	1854	1759.0	52	51	2074	122.8	86.7	42.5
1650	66	300	12	38	1676	2032	1930.4	52	51	2252	144.7	107.0	43.3
1800	72	300	12	38	1829	2197	2095.5	60	51	2417	167.0	121.9	42.7
1950	78	300	12	38	1981	2362	2260.6	64	54	2611	192.0	136.1	53.4
2100	84	300	12	38	2134	2534	2425.7	64	54	2783	210.1	150.1	63.7
2250	90	300	12	38	2286	2705	2591.0	68	60	2979	227.6	198.4	84.2
2400	96	300	12	38	2438	2877	2755.9	68	60	3165	253.9	241.4	98.5
2550	102	300	12	38	2591	3048	2908.3	72	67	3336	271.9	248.2	103.5
2700	108	300	12	38	2743	3219	3067.1	72	67	3506	295.1	265.6	105.6
3000	120	300	12	38	3048	3562	3371.9	76	73	3849	339.3	330.6	113.3
3300	132	300	12	38	3353	3905	3702.1	80	79	4205	385.6	400.8	116.9
3600	144	300	12	38	3658	4248	4019.6	84	86	4523	433.1	464.0	126.0

- Flange dimensions shown are in accordance with 150 lbs. standards of ANSI/ASME B16.5 Class 150, ANSI/ASME B16.47 Class 150 Series A and AWWA C207 Class D 150lbs.
- Weights of expansion joint, retaining ring and control rod set are based on Kurbo standard construction and may vary with selection of rubber/steel material and amount of reinforcements.
- 1 Control rod set consists of 1 control rod, 2 control rod plates, 4 washers and 8 nuts.
- Control rods are recommended for all applications. To ensure correct length, customer should provide thickness of mating flange or flange specification.

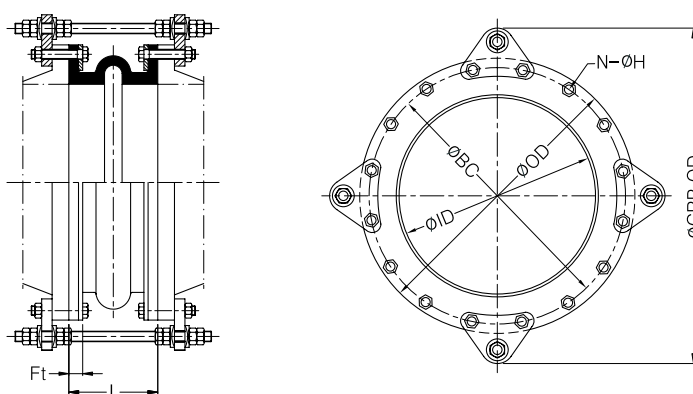

**Dimension and Weight - PN 10 Drill**

Nominal Size		Min. Length		Dimensions - PN 10							Weights (kg)		
DN	inch	mm	inch	Ft (mm)	I.D (mm)	O.D. (mm)	B.C. (mm)	No. of Holes(N)	Hole Dia. (N)	CRP O.D.	Exp Joint	Retaining Ring Set	Control Rod Set(1)
25	1	150	6	22	25	115	85	4	14	190	0.6	1.1	1.1
32	1.25	150	6	22	32	140	100	4	18	217	0.9	1.6	1.4
40	1.5	150	6	22	38	150	110	4	18	226	1.0	1.9	1.3
50	2	150	6	22	51	165	125	4	18	254	1.2	2.2	1.8
65	2.5	150	6	22	64	185	145	4	18	274	1.6	2.5	2.0
80	3	150	6	22	76	200	160	8	18	290	1.8	2.7	1.6
100	4	150	6	22	102	220	180	8	18	310	2.2	2.9	1.7
125	5	150	6	24	127	250	210	8	18	340	3.0	3.4	1.8
150	6	150	6	24	152	285	240	8	22	375	3.6	4.4	2.3
200	8	150	6	27	203	340	295	8	22	445	5.2	5.7	3.2
250	10	200	8	27	254	395	350	12	22	507	7.8	7.0	4.4
300	12	200	8	27	305	445	400	12	22	568	10.0	7.3	5.3
350	14	200	8	30	356	505	460	16	22	629	12.6	8.8	5.1
400	16	200	8	30	406	565	515	16	26	701	14.6	10.7	6.7
450	18	200	8	30	457	615	565	20	26	750	16.2	12.0	6.5
500	20	200	8	33	508	670	620	20	26	806	18.9	13.9	6.7
550	22	250	10	33	559	730	675	20	30	879	21.8	15.7	10.3
600	24	250	10	33	600	780	725	20	30	928	28.2	18.4	10.5
650	26	250	10	33	650	835	780	24	30	983	32.3	19.0	10.2
700	28	250	10	33	700	895	840	24	30	1053	35.6	22.6	13.2
750	30	250	10	33	750	965	900	24	33	1134	39.7	28.3	16.0
800	32	250	10	33	800	1015	950	24	33	1186	42.2	30.1	16.5
900	36	250	10	33	900	1115	1050	28	33	1303	47.9	33.0	20.1
1000	40	250	10	33	1000	1230	1160	28	36	1407	54.6	40.4	21.4
1100	44	300	12	38	1100	1340	1270	32	36	1522	78.0	43.4	21.8
1200	48	300	12	38	1200	1455	1380	32	39	1649	88.1	51.8	25.9
1300	52	300	12	38	1300	1575	1490	32	42	1769	100.0	62.7	27.6
1400	56	300	12	38	1400	1675	1590	36	42	1896	110.1	66.6	33.4
1500	60	300	12	38	1500	1785	1700	36	42	2006	121.7	74.1	36.8
1600	64	300	12	38	1600	1915	1820	40	48	2134	138.7	89.5	40.2
1800	72	300	12	38	1800	2115	2020	44	48	2335	155.3	98.6	40.3
2000	80	300	12	38	2000	2325	2230	48	48	2557	174.7	113.3	52.3
2200	88	300	12	38	2200	2550	2440	52	56	2802	202.8	133.9	68.3
2400	96	300	12	38	2400	2760	2650	56	56	3018	223.9	151.9	73.9
2600	104	300	12	38	2600	2960	2850	60	56	3216	242.0	163.6	76.1
2800	112	300	12	38	2800	3180	3070	64	56	3436	272.8	190.9	78.3
3000	120	300	12	38	3000	3405	3290	68	62	3660	298.7	218.5	83.7

1. Flange dimensions shown are in accordance with ISO PN10
2. Weights of expansion joint, retaining ring and control rod set are based on Kurbo standard construction and may vary with selection of rubber/steel material and amount of reinforcements.
3. 1 Control rod set consists of 1 control rod, 2 control rod plates, 4 washers and 8 nuts.
4. Control rods are recommended for all applications. To ensure correct length, customer should provide thickness of mating flange or flange specification.

## Type 22W Two Open Wide Arch

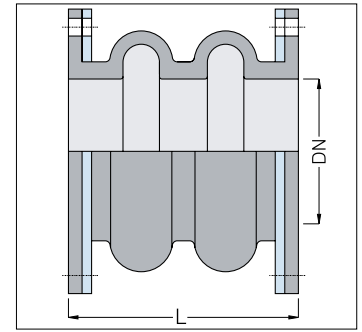
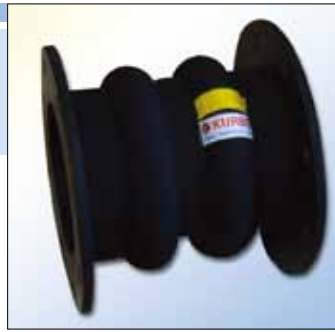

### Movement • Pressure • Weight

Nominal Size		Min. Length		Movement Capability				Max. Pressure (bar)	Vacuum Rating (mmHg)	Weights (kg)		
DN	inch	mm	inch	Comp. (mm)	Ext. (mm)	Lat. (mm)	Ang. (deg.)			Exp Joint	Retaining Ring Set	Control Rod Set (1)
25	1	250	10	40	20	24	57.6	12	600	0.8	0.8	1.3
32	1.25	250	10	40	20	24	51.6	12	600	1.0	1.0	1.4
40	1.5	250	10	40	20	24	46.4	12	600	1.2	1.1	1.4
50	2	250	10	70	35	32	54.0	12	600	1.5	1.6	2.3
65	2.5	250	10	70	35	32	47.8	12	600	2.2	2.2	2.6
80	3	250	10	70	35	32	42.6	12	600	2.5	2.3	2.6
100	4	250	10	70	35	32	34.6	12	600	3.3	3.3	2.2
125	5	250	10	80	40	36	32.2	12	600	4.3	3.5	2.4
150	6	250	10	80	40	36	27.7	12	600	5.0	3.9	2.8
200	8	250	10	80	40	36	21.5	10	600	7.4	5.9	4.1
250	10	350	14	80	40	36	17.5	10	600	12.4	7.8	6.1
300	12	350	14	80	40	40	14.7	10	600	17.1	11.4	7.5
350	14	350	14	80	40	40	12.7	10	600	20.9	12.7	8.2
400	16	350	14	80	40	40	11.1	8	600	24.2	14.7	9.3
450	18	350	14	80	40	40	9.9	8	600	24.9	16.0	9.7
500	20	350	14	80	40	40	8.9	8	600	29.1	17.9	9.5
550	22	400	16	100	50	46	10.1	8	600	36.2	18.3	13.8
600	24	400	16	100	50	46	9.3	8	600	40.8	21.5	14.3
650	26	400	16	100	50	46	8.6	7	600	46.5	23.6	14.1
700	28	400	16	100	50	46	8.0	7	600	50.3	25.9	17.6
750	30	400	16	100	50	46	7.5	7	500	54.3	29.4	20.6
800	32	400	16	100	50	46	7.0	7	500	59.7	37.5	22.3
850	34	400	16	100	50	46	6.6	7	500	64.2	37.8	25.7
900	36	400	16	100	50	46	6.2	7	500	68.5	40.2	27.8
950	38	400	16	100	50	46	5.9	7	500	74.4	50.0	28.4
1000	40	400	16	100	50	46	5.6	7	500	77.9	50.9	24.8
1050	42	400	16	120	60	50	6.4	6	400	90.8	52.6	26.9
1100	44	400	16	120	60	50	6.1	6	400	95.6	56.3	26.5
1150	46	400	16	120	60	50	5.9	6	400	102.1	57.9	26.8
1200	48	400	16	120	60	50	5.6	6	400	107.1	63.1	29.9
1250	50	400	16	120	60	50	5.4	6	400	111.0	63.3	31.7
1300	52	400	16	120	60	50	5.2	6	400	116.7	70.1	32.1
1350	54	400	16	120	60	50	5.0	6	400	127.7	73.8	41.7
1400	56	450	18	120	60	50	4.8	6	400	149.5	80.4	41.5
1450	58	450	18	120	60	50	4.7	6	400	156.0	86.7	41.9
1500	60	450	18	120	60	50	4.5	6	400	162.7	86.7	45.1
1650	66	450	18	120	60	50	4.1	6	400	190.1	107.0	45.9
1800	72	450	18	120	60	50	3.8	5	400	217.2	121.9	45.2
1950	78	450	18	120	60	50	3.5	5	400	249.7	136.1	56.9
2100	84	450	18	120	60	50	3.2	5	400	271.3	150.1	67.2
2250	90	450	18	120	60	50	3.0	4	400	293.2	198.4	88.7
2400	96	450	18	120	60	50	2.8	4	400	329.2	241.4	103.6
2550	102	450	18	120	60	50	2.7	4	300	351.9	248.2	108.6
2700	108	450	18	120	60	50	2.5	4	300	379.8	265.6	110.8
3000	120	450	18	120	60	50	2.3	3	300	433.3	330.6	118.4
3300	132	450	18	120	60	50	2.0	3	300	489.0	400.8	122.0
3600	144	450	18	120	60	50	1.9	3	300	545.9	464.0	129.7

1. All flange drilling available with different length, different arch shapes
2. Higher pressure and vacuum rating available upon request
3. Movements of the Type F22W, two filled arch design are 50% of movement capabilities of the 22W.
4. Weights of expansion joint, retaining ring and control rod set are based on Kurbo standard construction with ANSI 150 lbs drill pattern and may vary with selection of rubber/steel material and amount of reinforcements.
5. Control rods are recommended for all applications. To ensure correct length, customer should provide thickness of mating flange or flange specification.

# Type 23W Three Open Wide Arch

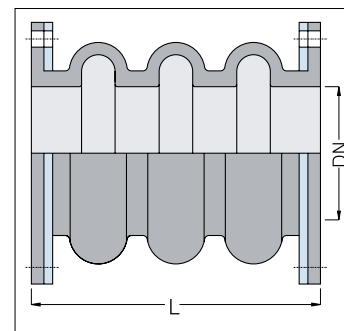

## Movement · Pressure · Weight

Nominal Size		Min. Length		Movement Capability				Max. Pressure (bar)	Vacuum Rating (mmHg)	Weights (kg)		
DN	inch	mm	inch	Comp. (mm)	Ext. (mm)	Lat. (mm)	Ang. (deg.)			Exp Joint	Retaining Ring Set	Control Rod Set (1)
25	1	350	14	60	30	36	67.1	12	400	1.0	0.8	1.4
32	1.25	350	14	60	30	36	62.1	12	400	1.3	1.0	1.5
40	1.5	350	14	60	30	36	57.6	12	400	1.5	1.1	1.5
50	2	350	14	105	52	48	64.2	12	400	2.0	1.6	2.5
65	2.5	350	14	105	52	48	58.8	12	400	2.8	2.2	2.7
80	3	350	14	105	52	48	54.0	12	400	3.3	2.3	2.8
100	4	350	14	105	52	48	45.9	12	400	4.3	3.3	2.4
125	5	350	14	120	60	54	43.4	12	400	5.6	3.5	2.5
150	6	350	14	120	60	54	38.2	12	400	6.6	3.9	2.9
200	8	350	14	120	60	54	30.6	10	400	9.6	5.9	4.4
250	10	450	18	120	60	54	25.3	10	400	15.2	7.8	6.4
300	12	450	18	120	60	60	21.5	10	400	20.8	11.4	7.9
350	14	450	18	120	60	60	18.6	10	400	25.3	12.7	8.6
400	16	450	18	120	60	60	16.5	8	400	29.2	16.0	9.8
450	18	450	18	120	60	60	14.7	8	400	30.4	14.7	10.3
500	20	450	18	120	60	60	13.3	8	400	35.2	17.9	10.0
550	22	500	20	150	75	69	15.0	8	400	43.3	18.3	14.5
600	24	500	20	150	75	69	13.8	8	400	48.5	21.5	15.0
650	26	500	20	150	75	69	12.8	7	400	55.1	23.6	14.7
700	28	500	20	150	75	69	11.9	7	400	59.5	25.9	18.4
750	30	500	20	150	75	69	11.1	7	300	64.2	29.4	21.6
800	32	500	20	150	75	69	10.5	7	300	70.2	37.5	23.3
850	34	500	20	150	75	69	9.9	7	300	75.5	37.8	26.8
900	36	500	20	150	75	69	9.3	7	300	80.5	40.2	29.2
950	38	500	20	150	75	69	8.8	7	300	87.0	50.0	29.7
1000	40	500	20	150	75	69	8.4	7	300	91.2	50.9	25.8
1050	42	550	22	180	90	75	9.6	6	300	115.2	52.6	28.5
1100	44	550	22	180	90	75	9.1	6	300	121.1	56.3	28.2
1150	46	550	22	180	90	75	8.8	6	300	130.0	57.9	28.5
1200	48	550	22	180	90	75	8.4	6	300	136.2	63.1	31.9
1250	50	550	22	180	90	75	8.1	6	300	141.4	63.3	33.7
1300	52	550	22	180	90	75	7.8	6	300	148.3	70.1	34.0
1350	54	550	22	180	90	75	7.5	6	250	163.1	73.8	44.2
1400	56	600	24	180	90	75	7.2	6	250	186.2	80.4	44.1
1450	58	600	24	180	90	75	7.0	6	250	194.0	86.7	44.5
1500	60	600	24	180	90	75	6.7	6	250	202.7	86.7	47.6
1650	66	600	24	180	90	75	6.1	6	250	235.5	107.0	48.4
1800	72	600	24	180	90	75	5.6	5	250	267.3	121.9	47.8
1950	78	600	24	180	90	75	5.2	5	250	307.5	136.1	60.4
2100	84	600	24	180	90	75	4.8	5	250	332.5	150.1	70.7
2250	90	600	24	180	90	75	4.5	4	250	358.7	198.4	93.2
2400	96	600	24	180	90	75	4.2	4	250	404.5	241.4	108.7
2550	102	600	24	180	90	75	4.0	4	250	431.9	248.2	113.8
2700	108	600	24	180	90	75	3.8	4	250	464.5	265.6	115.9
3000	120	600	24	180	90	75	3.4	3	250	527.4	330.6	123.5
3300	132	600	24	180	90	75	3.1	3	250	592.4	400.8	127.2
3600	144	600	24	180	90	75	2.8	3	250	658.7	464.0	134.9

1. All flange drilling available with different length, different arch shapes
2. Higher pressure and vacuum rating available upon request
3. Movements of the Type F23W, three filled arch design are 50% of movement capabilities of the 23W.
4. Weights of expansion joint, retaining ring and control rod set are based on Kurbo standard construction with ANSI 150 lbs drill pattern and may vary with selection of rubber/steel material and amount of reinforcements.
5. Control rods are recommended for all applications. To ensure correct length, customer should provide thickness of mating flange or flange specification.



# Type 24W Four Open Wide Arch

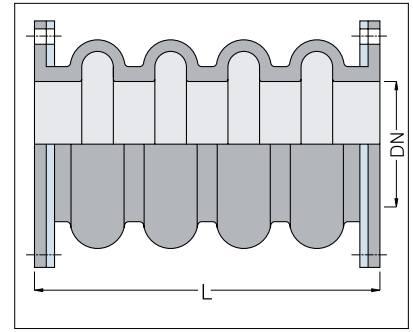

**Movement · Pressure · Weight**

Nominal Size		Min. Length		Movement Capability				Max. Pressure (bar)	Vacuum Rating (mmHg)	Weights (kg)		
DN	inch	mm	inch	Comp. (mm)	Ext. (mm)	Lat. (mm)	Ang. (deg.)			Exp Joint	Retaining Ring Set	Control Rod Set (1)
25	1	400	16	80	40	48	72.4	12	400	1.1	0.8	1.5
32	1.25	400	16	80	40	48	68.4	12	400	1.4	1.0	1.5
40	1.5	400	16	80	40	48	64.5	12	400	1.7	1.1	1.6
50	2	450	18	140	70	64	70.1	12	400	2.4	1.6	2.7
65	2.5	450	18	140	70	64	65.6	12	400	3.5	2.2	2.9
80	3	450	18	140	70	64	61.4	12	400	4.0	2.3	3.0
100	4	450	18	140	70	64	54.0	12	400	5.3	3.3	2.5
125	5	450	18	160	80	72	51.6	12	400	6.9	3.5	2.7
150	6	450	18	160	80	72	46.4	12	400	8.1	3.9	3.1
200	8	450	18	160	80	72	38.2	10	400	11.7	5.9	4.7
250	10	500	20	160	80	72	32.2	10	400	16.4	7.8	6.6
300	12	500	20	160	80	80	27.7	10	400	22.3	11.4	8.2
350	14	500	20	160	80	80	24.2	10	400	27.0	12.7	8.9
400	16	500	20	160	80	80	21.5	8	400	31.1	16.0	10.1
450	18	500	20	160	80	80	19.3	8	400	32.7	14.7	10.6
500	20	500	20	160	80	80	17.5	8	400	37.8	17.9	10.3
550	22	600	24	200	100	92	19.7	8	400	50.3	18.3	15.2
600	24	600	24	200	100	92	18.2	8	400	56.3	21.5	15.7
650	26	600	24	200	100	92	16.8	7	400	63.7	23.6	15.4
700	28	600	24	200	100	92	15.7	7	400	68.7	25.9	19.3
750	30	600	24	200	100	92	14.7	7	300	74.1	29.4	22.6
800	32	600	24	200	100	92	13.8	7	300	80.7	37.5	24.3
850	34	600	24	200	100	92	13.0	7	300	86.7	37.8	28.0
900	36	600	24	200	100	92	12.3	7	300	92.4	40.2	30.5
950	38	600	24	200	100	92	11.7	7	300	99.6	50.0	31.1
1000	40	600	24	200	100	92	11.1	7	300	104.4	50.9	26.8
1050	42	700	28	240	120	100	12.7	6	300	139.6	52.6	30.2
1100	44	700	28	240	120	100	12.1	6	300	146.7	56.3	29.9
1150	46	700	28	240	120	100	11.6	6	300	158.0	57.9	30.2
1200	48	700	28	240	120	100	11.1	6	300	165.4	63.1	33.8
1250	50	700	28	240	120	100	10.7	6	300	171.8	63.3	35.6
1300	52	700	28	240	120	100	10.3	6	300	179.8	70.1	36.0
1350	54	700	28	240	120	100	9.9	6	250	198.4	73.8	46.8
1400	56	750	30	240	120	100	9.6	6	250	222.9	80.4	46.6
1450	58	750	30	240	120	100	9.3	6	250	231.9	86.7	47.0
1500	60	750	30	240	120	100	8.9	6	250	242.6	86.7	50.2
1650	66	750	30	240	120	100	8.1	6	250	280.9	107.0	51.0
1800	72	750	30	240	120	100	7.5	5	250	317.5	121.9	50.3
1950	78	750	30	240	120	100	6.9	5	250	365.2	136.1	63.9
2100	84	750	30	240	120	100	6.4	5	250	393.7	150.1	74.1
2250	90	750	30	240	120	100	6.0	4	250	424.2	198.4	97.7
2400	96	750	30	240	120	100	5.6	4	250	479.8	241.4	113.9
2550	102	750	30	240	120	100	5.3	4	250	511.9	248.2	118.9
2700	108	750	30	240	120	100	5.0	4	250	549.1	265.6	121.0
3000	120	750	30	240	120	100	4.5	3	250	621.4	330.6	128.7
3300	132	750	30	240	120	100	4.1	3	250	695.8	400.8	132.3
3600	144	750	30	240	120	100	3.8	3	250	771.5	464.0	140.0

1. All flange drilling available with different length, different arch shapes
2. Higher pressure and vacuum rating available upon request
3. Movements of the Type F24W, four filled arch design are 50% of movement capabilities of the 24W.
4. Weights of expansion joint, retaining ring and control rod set are based on Kurbo standard construction with ANSI 150 lbs drill pattern and may vary with selection of rubber/steel material and amount of reinforcements.
5. Control rods are recommended for all applications. To ensure correct length, customer should provide thickness of mating flange or flange specification.

# Type F21W One Filled Arch

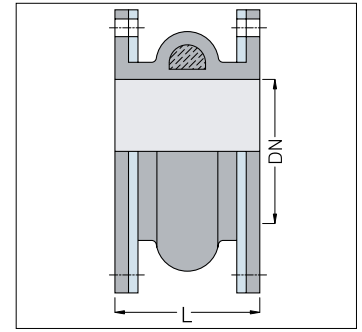

## Features

- Used to reduce flow turbulence and prevent collection of solid material inside the arch, ensuring free fluid flow.
- Ideal for lines carrying heavy slurry or suspension.
- Also recommended for systems where high flow velocity and high abrasion conditions exist.
- The same movements as single open spool arch type joints

## Movement • Pressure • Weight

Nominal Size		Min. Length		Movement Capability				Max. Pressure (bar)	Vacuum Rating (mmHg)	Weights (kg)		
				Comp. (mm)	Ext. (mm)	Lat. (mm)	Ang. (deg.)			Exp Joint	Retaining Ring Set	Control Rod Set (1)
DN	inch	mm	inch									
25	1	150	6	10	5	6	21.5	12	760	0.7	0.8	1.2
32	1.25	150	6	10	5	6	17.5	12	760	0.8	1.0	1.3
40	1.5	150	6	10	5	6	14.7	12	760	0.9	1.1	1.3
50	2	150	6	17	8	8	19.0	12	760	1.3	1.6	2.2
65	2.5	150	6	17	8	8	15.4	12	760	1.8	2.2	2.4
80	3	150	6	17	8	8	12.9	12	760	2.1	2.3	2.5
100	4	150	6	17	8	8	9.8	12	760	2.7	3.3	2.0
125	5	150	6	20	10	9	8.9	12	760	3.8	3.5	2.2
150	6	150	6	20	10	9	7.5	12	760	4.4	3.9	2.6
200	8	150	6	20	10	9	5.6	10	760	6.4	5.9	3.8
250	10	200	8	20	10	9	4.5	10	760	9.5	7.8	5.5
300	12	200	8	20	10	10	3.8	10	760	13.4	11.4	6.9
350	14	200	8	20	10	10	3.2	10	760	16.2	12.7	7.6
400	16	200	8	20	10	10	2.8	8	760	18.9	16.0	8.5
450	18	200	8	20	10	10	2.5	8	760	19.3	14.7	9.0
500	20	200	8	20	10	10	2.3	8	760	22.8	17.9	8.7
550	22	250	10	25	12	11	2.6	8	760	31.1	18.3	12.9
600	24	250	10	25	12	11	2.3	8	760	35.0	21.5	13.4
650	26	250	10	25	12	11	2.2	7	760	39.5	23.6	13.1
700	28	250	10	25	12	11	2.0	7	760	42.7	25.9	16.4
750	30	250	10	25	12	11	1.9	7	760	46.1	29.4	19.2
800	32	250	10	25	12	11	1.8	7	760	50.9	37.5	20.9
850	34	250	10	25	12	11	1.7	7	760	54.4	37.8	24.0
900	36	250	10	25	12	11	1.6	7	760	58.2	40.2	25.9
950	38	250	10	25	12	11	1.5	7	760	63.5	50.0	26.5
1000	40	250	10	25	12	11	1.4	7	760	66.4	50.9	23.4
1050	42	300	12	30	15	12	1.6	6	760	88.3	52.6	25.6
1100	44	300	12	30	15	12	1.5	6	760	93.0	56.3	25.3
1150	46	300	12	30	15	12	1.5	6	760	98.1	57.9	25.6
1200	48	300	12	30	15	12	1.4	6	760	102.9	63.1	28.5
1250	50	300	12	30	15	12	1.4	6	760	106.7	63.3	30.3
1300	52	300	12	30	15	12	1.3	6	760	112.2	70.1	30.7
1350	54	300	12	30	15	12	1.3	6	760	124.6	73.8	39.8
1400	56	300	12	30	15	12	1.2	6	760	131.6	80.4	38.9
1450	58	300	12	30	15	12	1.2	6	760	137.5	86.7	39.4
1500	60	300	12	30	15	12	1.1	6	760	142.8	86.7	42.5
1650	66	300	12	30	15	12	1.0	6	760	166.7	107.0	43.3
1800	72	300	12	30	15	12	0.9	5	760	190.9	121.9	42.7
1950	78	300	12	30	15	12	0.9	5	760	217.8	136.1	53.4
2100	84	300	12	30	15	12	0.8	5	760	241.3	150.1	63.7
2250	90	300	12	30	15	12	0.8	4	760	261.0	198.4	84.2
2400	96	300	12	30	15	12	0.7	4	760	289.4	241.4	98.5
2550	102	300	12	30	15	12	0.7	4	760	309.6	248.2	103.5
2700	108	300	12	30	15	12	0.6	4	760	334.9	265.6	105.6
3000	120	300	12	30	15	12	0.6	3	760	383.4	330.6	113.3
3300	132	300	12	30	15	12	0.5	3	760	434.0	400.8	116.9
3600	144	300	12	30	15	12	0.5	3	760	485.8	464.0	126.0

1. Weights of expansion joint, retaining ring and control rod set are based on Kurbo standard construction with ANSI 150 lbs drill pattern and may vary with selection of rubber/steel material and amount of reinforcements.
2. Control rods are recommended for all applications. To ensure correct length, customer should provide flange specification.

## Series 10 Spool Arch Type Expansion Joint

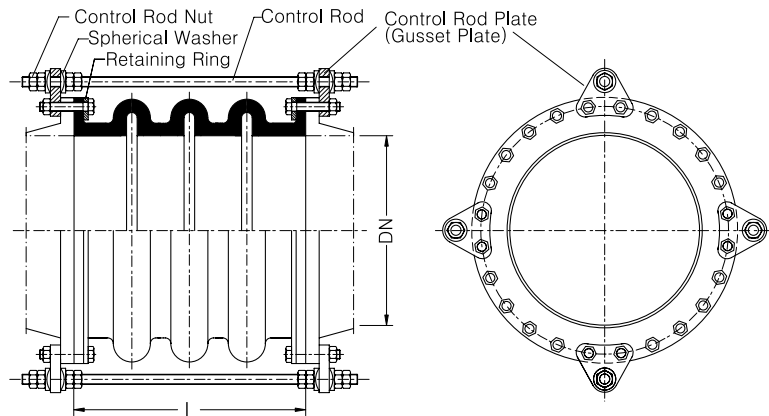

### Use

With the introduction of Kurbo Series 20W wide arch type expansion joints, The Series 10 conventional products have been used only for replacement purpose and used in a specific piping condition requiring shortest installation length between two connecting flanges.

The 20W is improved design of the 10 spool arch type joint in an attempt to provide much greater movement and lower spring rate capability with shorter joint length. Thus, they eliminate the needs for double or multiple arch spool type joints resulting in less cost.

With these advantages, we recommend you the 20W unless the installation length is an important consideration. For engineering data such as expansion joint length, movement, spring rate and pressure capability, please see the tables below and on next page.

### Expansion Joint Length Comparison between Series 10 and 20W

Normal Size		Minimum Length of Series 10 and 20W - mm							
		1 Arch		2 Arch		3 Arch		4 Arch	
DN	inch	11	21W	12	22W	13	23W	14	24W
25 - 40	1 - 1.5	130	150	230	250	300	350	350	400
50 - 200	2 - 8	140	150	230	250	300	350	350	450
250 - 300	10 - 12	150	200	300	350	350	450	400	500
350 - 500	14 - 20	180	200	300	350	400	450	500	500
550 - 1000	22 - 40	220	250	350	400	450	500	550	600
1050 - 1350	42 - 54	220	300	350	400	450	550	600	700
1400 - 1800	56 - 72	230	300	350	450	450	600	600	750
1950 - 2400	78 - 96	250	300	400	450	450	600	600	750
2550 - 3600	102 - 144	280	300	400	450	500	600	600	750

1. Series 10 (Type 11, 12, 13 and 14) : Conventional spool arch type expansion joint

2. Series 20W (Type 21W, 22W, 23W and 24W) : New wide arch type expansion joint

**Movement · Spring Rate · Pressure Rating**

Nominal Size		Recommended Length		Movement Capability				Spring Rates			Max. Pressure	Vacuum Rating
				Comp.	Ext.	Lat.	Ang.	Comp.	Ext.	Lat.		
DN	inch	mm	inch	(mm)	(mm)	(mm)	(deg.)	(kg/mm)	(kg/mm)	(kg/mm)	(bar)	(mmHg)
25*	1	150	6	12	6	12	25.5	4.1	5.3	6.1	14	760
32*	1.25	150	6	12	6	12	20.6	5.1	6.6	7.6	14	760
40*	1.5	150	6	12	6	12	16.7	6.1	8.1	9.1	14	760
50	2	150	6	12	6	12	13.5	7.6	9.9	12.5	14	760
65	2.5	150	6	12	6	12	10.5	9.5	12.3	13.6	14	760
80	3	150	6	12	6	12	9.1	11.3	14.8	14.7	14	760
100	4	150	6	12	6	12	7.6	15.1	19.7	17.0	14	760
125	5	150	6	12	6	12	5.5	18.9	24.6	19.5	13	760
150	6	150	6	12	6	12	4.6	22.7	29.5	22.0	13	760
200	8	150	6	19	9	12	5.4	25.2	32.8	26.9	10	760
250	10	200	8	19	9	12	4.3	31.5	41.0	28.9	10	760
300	12	200	8	19	9	12	3.6	37.8	49.2	33.9	10	760
350	14	200	8	19	9	12	3.1	33.1	43.1	39.9	10	760
400	16	200	8	19	9	12	2.7	37.8	49.2	45.9	8	760
450	18	200	8	19	9	12	2.4	42.5	55.4	50.7	8	760
500	20	200	8	22	11	12	2.5	47.3	61.4	56.7	8	760
550	22	250	10	22	11	12	2.3	52.0	67.6	58.9	8	760
600	24	250	10	22	11	12	2.1	56.8	73.8	60.9	8	760
650	26	250	10	25	12	12	2.2	54.7	71.1	65.3	7	760
700	28	250	10	25	12	12	2.0	58.9	76.5	69.7	7	760
750	30	250	10	25	12	12	1.9	63.1	82.0	74.1	7	760
800	32	250	10	25	12	12	1.8	67.3	87.5	87.1	7	760
850	34	250	10	25	12	12	1.7	71.5	100.1	100.1	7	760
900	36	250	10	25	12	12	1.6	75.7	98.4	113.0	7	760
950	38	250	10	25	12	12	1.5	79.9	103.9	116.1	7	760
1000	40	250	10	25	12	12	1.4	84.1	109.4	119.2	7	760
1050	42	300	12	28	14	12	1.4	79.5	103.3	122.3	6	760
1100	44	300	12	28	14	12	1.5	83.3	108.2	127.6	6	760
1150	46	300	12	28	14	12	1.4	87.0	113.2	132.8	6	760
1200	48	300	12	28	14	12	1.3	90.9	118.0	138.1	6	760
1250	50	300	12	28	14	12	1.3	94.7	122.9	143.3	6	760
1300	52	300	12	28	14	12	1.2	98.4	128.0	148.5	6	760
1350	54	300	12	28	14	12	1.2	102.2	132.8	153.7	6	760
1400	56	300	12	28	14	12	1.1	106.0	137.8	158.9	6	760
1450	58	300	12	28	14	12	1.1	109.8	142.7	164.0	6	760
1500	60	300	12	28	14	12	1.1	113.6	147.7	169.2	6	760
1650	66	300	12	28	14	12	1.0	124.9	162.4	182.5	6	760
1800	72	300	12	28	14	12	0.9	136.3	177.2	195.6	5	760
1950	78	300	12	28	14	12	0.9	147.7	192.0	212.6	5	700
2100	84	300	12	28	14	12	0.8	159.0	206.7	229.5	5	700
2400	96	300	12	28	14	12	0.7	181.7	236.3	263.4	4	700
2550	102	300	12	28	14	12	0.7	193.1	251.0	280.4	4	700
2700	108	300	12	28	14	12	0.6	204.5	265.8	297.4	4	700
3000	120	300	12	28	14	12	0.6	227.2	295.4	331.3	3	700
3300	132	300	12	28	14	12	0.5	249.9	324.9	362.3	3	700
3600	144	300	12	28	14	12	0.4	272.6	354.4	393.4	3	700

- \*items are normally furnished with "Filled Arch" construction.
- Spring rates are based on single open arch at zero pressure conditions, therefore, should be considered only as approximate.
- To obtain movement of multiple arch type expansion joints, take the movement shown above and multiply by the number of arches or contact Kurbo.
- Contact Kurbo for forces of multiple and filled arch products.
- Control rods are recommended for all applications. To ensure correct length, customer should provide thickness of mating flange or flange specification.

## Series 20UG Underground Type Expansion Joint



### Burial Application

Buried pipelines are directly affected by the external loads produced by weight of earth, traffic load, the ground shifting created by uneven sinking of ground and earthquake. The uneven sinking between rigid structure and ground is most detrimental for underground piping. To solve such differential settlement problems, Kurbo offers Winflex Series 20UG for direct burial application.

### Type Available

- 21UG & 22UG : For standard lateral and axial movements.
- 23UG & 24UG : For 100mm & 200mm lateral and normal axial movements.
- 22GB-3 & 22GB-4 : For 300mm & 400mm lateral and normal axial movements.
- 23UG-PL & 24UG-PL : For 100mm & 200mm lateral and normal axial movements in plastic piping.

### Features

- Absorb ground/foundation settlement and seismic displacements.
- Prevent any damage or breakage of underground pipeline caused by ground motion like uneven ground sinking or earthquake.
- Designed to withstand external load of over 2 meters of earth weight plus another vehicle load of two 20tons trucks. For greater loads, please contact Kurbo.
- Compensate for differential settlement up to 400mm.
- Available in single, double, triple, multiple arch configurations
- Unique ability to accommodate large lateral movement with short overall length.
- Lateral offset capability can be adjusted with longer length.
- Superior reliability and durability—Extended service life: Use of quality materials, optimum selection of construction and professional workmanship allow Kurbo 20UG to guarantee longer service life.
- Wide variety of elastomers: As a standard elastomers, choice of natural, neoprene, nitrile, butyl, EPDM, CSM elastomers are available. As a special, Viton, Teflon and more available. Please refer to Kurbo "Chemical Resistance Guide" for recommendations on elastomer best suited for the chemical/process fluid in your system.
- Specially formulated rubber has great recovery from movement. Unique ability to return to its original shape.
- Wide range of size, length and connection available
- Excellent corrosion resistance

### ***Solution to Differential Settlement Problems:***

*Prevent any damage of underground piping by accommodating differential settlement caused by uneven ground-level change or seismic activity.*

## CONSTRUCTION

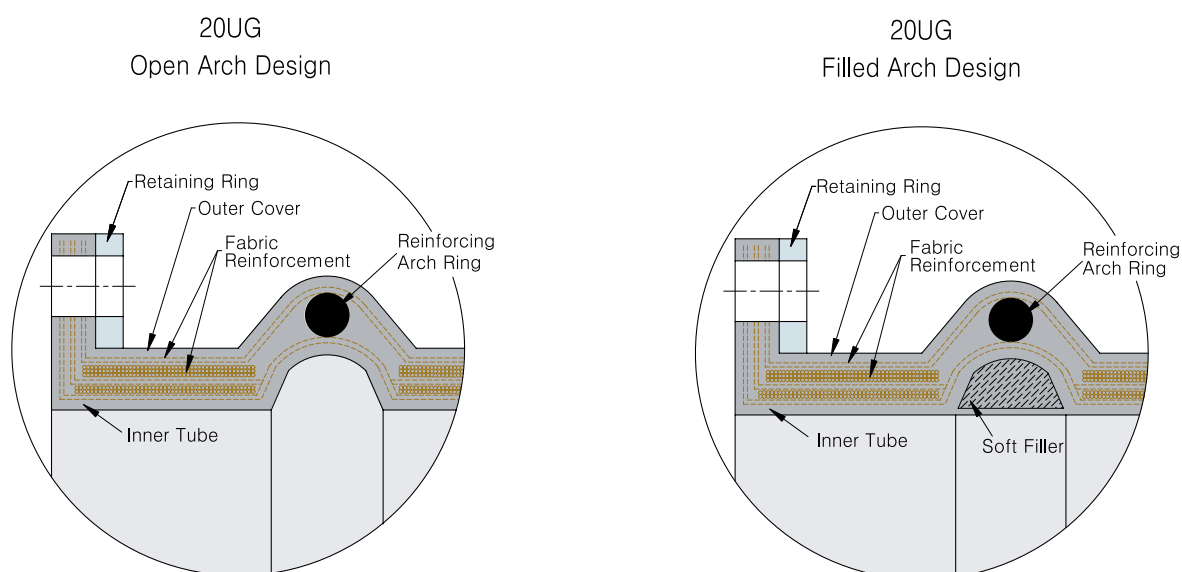

### **Inner Tube**

The inner tube protects the fabric and metal reinforcements from penetration of the media/fluid.

The smooth, leakproof inner tube can be designed to cover a variety of service conditions for chemical, petroleum, sewage, abrasive and corrosive materials etc.

### **Fabric Reinforcement**

The body fabric reinforcement is flexible and supporting member between the inner tube and outer cover. Different fabrics are used depending upon the service conditions such as pressure, temperature. All fabric plies are impregnated with rubber to permit flexibility between the fabric plies.

### **Reinforcing Arch Ring and Wire**

The reinforcing ring at the top of the arch to resist the external forces produced by weight of earth, vehicle load etc. This ring is generally used for direct burial application and vacuum service. In some case, reinforcing steel wires are used over and/or below the fabric plies to provide more strength and rigidity to the expansion joint.

### **Outer Cover**

The outer cover protects the body fabric and metal reinforcements from external conditions. Generally made of synthetic rubber having good resistance to weather, ozone, aging and corrosion.

### **Retaining Ring**

All Kurbo Winflex Series 20UG require steel retaining rings. They distribute bolting pressure evenly around the mating flanges and prevent rubber flange damage when tightened. Typical retaining ring material is galvanized mild steel.

## Type 21UG For 20mm Lateral Deflection

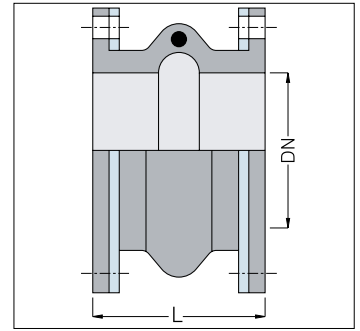

### Movement · Pressure · Weight

Nominal Size		Min. Length		No. of Arch	Movement Capability				Max. Pressure (bar)	Vacuum Rating (mmHg)	Weight (kg)	
					Lateral (mm)	Comp. (mm)	Ext. (mm)	Ang. (deg)			Exp Joint	Retaining Ring set
DN	inch	mm	inch									
25	1	150	6	1	20	20	15	49.7	10	760	0.6	0.8
32	1.25	150	6	1	20	20	15	43.4	10	760	0.8	1.0
40	1.5	150	6	1	20	20	15	38.2	10	760	0.9	1.2
50	2	150	6	1	20	20	15	30.6	10	760	1.2	1.7
65	2.5	150	6	1	20	20	15	25.3	10	760	1.5	2.4
80	3	150	6	1	20	20	20	27.7	10	760	2.1	2.5
100	4	150	6	1	20	20	20	21.5	10	760	2.7	3.5
125	5	150	6	1	20	20	20	17.5	10	760	3.2	3.7
150	6	200	8	1	20	20	20	14.7	10	760	5.2	4.2
200	8	200	8	1	20	20	20	11.1	10	760	6.9	6.2
250	10	200	8	1	20	20	20	8.9	10	760	8.5	8.2
300	12	200	8	1	20	20	20	7.5	10	760	11.6	12.1
350	14	200	8	1	20	30	25	8.0	10	760	13.9	13.3
400	16	200	8	1	20	30	25	7.0	10	760	16.7	15.9
450	18	200	8	1	20	30	25	6.2	10	760	17.9	15.2
500	20	250	10	1	20	30	25	5.6	10	760	25.3	18.5
550	22	250	10	1	20	30	25	5.1	7	760	29.6	18.6
600	24	250	10	1	20	30	25	4.7	7	760	33.0	22.9
650	26	250	10	1	20	30	25	4.3	7	760	39.5	25.4
700	28	250	10	1	20	30	25	4.0	7	760	42.6	28.0
750	30	250	10	1	20	30	25	3.8	5	760	46.0	31.4
800	32	300	12	1	20	30	25	3.5	5	760	56.5	37.1
850	34	300	12	1	20	30	25	3.3	5	760	59.7	38.6
900	36	300	12	1	20	30	25	3.1	5	760	63.6	42.6
950	38	300	12	1	20	30	25	3.0	5	760	71.6	50.7
1000	40	300	12	1	20	30	25	2.8	5	760	75.0	52.5
1050	42	300	12	1	20	30	25	2.7	5	760	85.4	55.5
1100	44	300	12	1	20	30	25	2.6	5	760	89.7	59.3
1150	46	300	12	1	20	30	25	2.5	5	760	93.7	62.1
1200	48	300	12	1	20	30	25	2.3	5	760	102.0	66.2
1250	50	300	12	1	20	30	25	2.3	5	760	105.8	67.9
1300	52	300	12	1	20	30	25	2.2	5	760	111.0	73.6
1350	54	300	12	1	20	30	25	2.1	5	760	117.7	75.3
1400	56	300	12	1	20	30	25	2.0	5	760	128.6	83.9
1450	58	300	12	1	20	30	25	1.9	5	760	134.1	89.7
1500	60	300	12	1	20	30	25	1.9	5	760	137.6	89.9

- Weights of expansion joint and retaining ring set are based on Kurbo standard construction with ANSI 150 lbs flange drilling and may vary with selection of rubber/steel material and amount of reinforcements.
- Larger sizes up to DN3600 available upon request
- All flange drilling available with different length
- Higher pressure rating and greater movements are available upon request
- Movements shown are non-concurrent movements.

# Type 22UG

## For 50mm Lateral Deflection

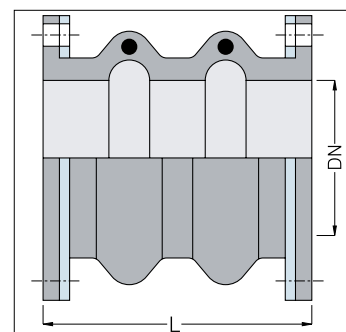

### Movement · Pressure · Weight

Nominal Size		Min. Length		No. of Arch	Movement Capability				Max. Pressure (bar)	Vacuum Rating (mmHg)	Weight (kg)	
					Lateral (mm)	Comp. (mm)	Ext. (mm)	Ang. (deg)			Exp Joint	Retaining Ring set
DN	inch	mm	inch									
25	1	250	10	2	50	45	30	67.1	10	760	1.0	0.8
32	1.25	250	10	2	50	45	30	62.1	10	760	1.1	1.0
40	1.5	250	10	2	50	45	30	57.6	10	760	1.3	1.2
50	2	250	10	2	50	45	30	49.7	10	760	1.8	1.7
65	2.5	250	10	2	50	45	30	43.4	10	760	2.2	2.4
80	3	300	12	2	50	45	30	38.2	10	760	3.5	2.5
100	4	300	12	2	50	45	30	30.6	10	760	4.5	3.5
125	5	300	12	2	50	45	30	25.3	10	760	5.6	3.7
150	6	300	12	2	50	45	30	21.5	10	760	7.9	4.2
200	8	300	12	2	50	45	30	16.5	10	760	10.4	6.2
250	10	300	12	2	50	45	30	13.3	10	760	12.8	8.2
300	12	300	12	2	50	45	30	11.1	10	760	16.8	12.1
350	14	350	14	2	50	50	40	12.7	10	760	22.3	13.3
400	16	350	14	2	50	50	40	11.1	10	760	26.7	15.9
450	18	350	14	2	50	50	40	9.9	10	760	29.1	15.2
500	20	350	14	2	50	50	40	8.9	10	760	37.6	18.5
550	22	400	16	2	50	50	40	8.1	7	760	47.0	18.6
600	24	400	16	2	50	50	40	7.5	7	760	51.8	22.9
650	26	400	16	2	50	50	40	6.9	7	760	63.5	25.4
700	28	400	16	2	50	50	40	6.4	7	760	68.4	28.0
750	30	400	16	2	50	50	40	6.0	5	760	73.5	31.4
800	32	400	16	2	50	50	40	5.6	5	760	80.8	37.1
850	34	400	16	2	50	50	40	5.3	5	760	85.4	38.6
900	36	400	16	2	50	50	40	5.0	5	760	90.8	42.6
950	38	400	16	2	50	50	40	4.7	5	760	103.1	50.7
1000	40	450	18	2	50	50	40	4.5	5	760	114.5	52.5
1050	42	450	18	2	50	50	40	4.3	5	760	128.8	55.5
1100	44	450	18	2	50	50	40	4.1	5	760	135.2	59.3
1150	46	450	18	2	50	50	40	3.9	5	760	141.1	62.1
1200	48	450	18	2	50	50	40	3.8	5	760	155.2	66.2
1250	50	450	18	2	50	50	40	3.6	5	760	161.2	67.9
1300	52	450	18	2	50	50	40	3.5	5	760	168.5	73.6
1350	54	450	18	2	50	50	40	3.3	5	760	177.6	75.3
1400	56	450	18	2	50	50	40	3.2	5	760	195.4	83.9
1450	58	450	18	2	50	50	40	3.1	5	760	203.1	89.7
1500	60	450	18	2	50	50	40	3.0	5	760	209.0	89.9

- Weights of expansion joint and retaining ring set are based on Kurbo standard construction with ANSI 150 lbs flange drilling and may vary with selection of rubber/steel material and amount of reinforcements.
- Larger sizes up to DN3600 available upon request
- All flange drilling available with different length
- Higher pressure rating and greater movements are available upon request
- Movements shown are non-concurrent movements.



## Type 23UG For 100mm Lateral Deflection

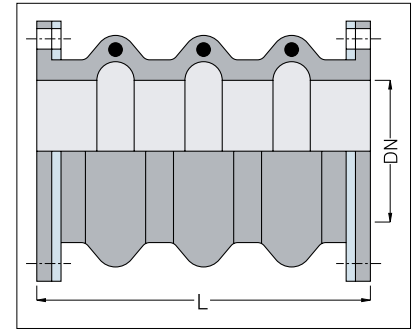

### Movement · Pressure · Weight

Nominal Size		Min. Length		No. of Arch	Movement Capability				Max. Pressure (bar)	Vacuum Rating (mmHg)	Weight (kg)	
					Lateral (mm)	Comp. (mm)	Ext. (mm)	Ang. (deg)			Exp Joint	Retaining Ring set
DN	inch	mm	inch									
25	1	350	14	3	100	60	40	72.4	10	760	1.3	0.8
32	1.25	350	14	3	100	60	40	68.4	10	760	1.5	1.0
40	1.5	350	14	3	100	60	40	64.5	10	760	1.7	1.2
50	2	350	14	3	100	60	40	57.6	10	760	2.3	1.7
65	2.5	350	14	3	100	60	40	51.6	10	760	2.9	2.4
80	3	350	14	3	100	60	40	46.4	10	760	4.3	2.5
100	4	350	14	3	100	60	40	38.2	10	760	5.5	3.5
125	5	350	14	3	100	60	40	32.2	10	760	6.8	3.7
150	6	500	20	3	100	60	40	27.7	10	760	12.1	4.2
200	8	500	20	3	100	60	40	21.5	10	760	15.8	6.2
250	10	500	20	3	100	60	40	17.5	10	760	20.5	8.2
300	12	550	22	3	100	60	40	14.7	10	760	26.4	12.1
350	14	550	22	3	100	70	50	15.7	10	760	32.5	13.3
400	16	550	22	3	100	70	50	13.8	10	760	38.6	15.9
450	18	550	22	3	100	70	50	12.3	10	760	42.5	15.2
500	20	550	22	3	100	70	50	11.1	10	760	54.9	18.5
550	22	550	22	3	100	70	50	10.1	7	760	62.6	18.6
600	24	550	22	3	100	70	50	9.3	7	760	70.5	22.9
650	26	650	26	3	100	70	50	8.6	7	760	92.7	25.4
700	28	650	26	3	100	70	50	8.0	7	760	102.4	28.0
750	30	650	26	3	100	70	50	7.5	5	760	109.7	31.4
800	32	650	26	3	100	70	50	7.0	5	760	120.7	37.1
850	34	650	26	3	100	70	50	6.6	5	760	125.2	38.6
900	36	650	26	3	100	70	50	6.2	5	760	135.5	42.6
950	38	650	26	3	100	70	50	5.9	5	760	150.2	50.7
1000	40	700	28	3	100	70	50	5.6	5	760	167.2	52.5
1050	42	700	28	3	100	70	50	5.4	5	760	187.3	55.5
1100	44	700	28	3	100	70	50	5.1	5	760	196.4	59.3
1150	46	700	28	3	100	70	50	4.9	5	760	202.0	62.1
1200	48	700	28	3	100	70	50	4.7	5	760	225.9	66.2
1250	50	700	28	3	100	70	50	4.5	5	760	234.6	67.9
1300	52	700	28	3	100	70	50	4.3	5	760	244.7	73.6
1350	54	700	28	3	100	70	50	4.2	5	760	258.8	75.3
1400	56	750	30	3	100	70	50	4.0	5	760	294.9	83.9
1450	58	750	30	3	100	70	50	3.9	5	760	306.1	89.7
1500	60	750	30	3	100	70	50	3.8	5	760	315.3	89.9

- Weights of expansion joint and retaining ring set are based on Kurbo standard construction with ANSI 150 lbs flange drilling and may vary with selection of rubber/steel material and amount of reinforcements.
- Larger sizes up to DN3600 available upon request
- All flange drilling available with different length
- Higher pressure rating and greater movements are available upon request
- Movements shown are non-concurrent movements.

# Type 24UG

## For 200mm Lateral Deflection

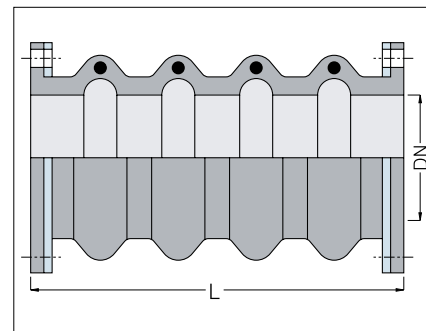

### Movement · Pressure · Weight

Nominal Size		Min. Length		No. of Arch	Movement Capability				Max. Pressure (bar)	Vacuum Rating (mmHg)	Weight (kg)	
DN	inch	mm	inch		Lateral (mm)	Comp. (mm)	Ext. (mm)	Ang. (deg)			Exp Joint	Retaining Ring set
25	1	450	18	4	200	70	50	75.7	10	760	1.6	0.8
32	1.25	450	18	4	200	70	50	72.4	10	760	1.9	1.0
40	1.5	450	18	4	200	70	50	69.1	10	760	2.2	1.2
50	2	450	18	4	200	70	50	63.1	10	760	2.9	1.7
65	2.5	450	18	4	200	70	50	57.6	10	760	3.6	2.4
80	3	450	18	4	200	70	50	52.7	10	760	5.4	2.5
100	4	450	18	4	200	70	50	44.5	10	760	7.0	3.5
125	5	450	18	4	200	70	50	38.2	10	760	8.6	3.7
150	6	600	24	4	200	70	50	33.3	10	760	14.9	4.2
200	8	600	24	4	200	70	50	26.2	10	760	19.4	6.2
250	10	600	24	4	200	70	50	21.5	10	760	23.8	8.2
300	12	650	26	4	200	70	50	18.2	10	760	31.6	12.1
350	14	650	26	4	200	80	60	18.6	10	760	39.3	13.3
400	16	650	26	4	200	80	60	16.5	10	760	46.5	15.9
450	18	650	26	4	200	80	60	14.7	10	760	51.2	15.2
500	20	650	26	4	200	80	60	13.3	10	760	67.1	18.5
550	22	650	26	4	200	80	60	12.1	7	760	76.2	18.6
600	24	650	26	4	200	80	60	11.1	7	760	85.7	22.9
650	26	750	30	4	200	80	60	10.3	7	760	104.6	25.4
700	28	750	30	4	200	80	60	9.6	7	760	124.1	28.0
750	30	750	30	4	200	80	60	8.9	5	760	132.9	31.4
800	32	750	30	4	200	80	60	8.4	5	760	145.1	37.1
850	34	750	30	4	200	80	60	7.9	5	760	150.2	38.6
900	36	750	30	4	200	80	60	7.5	5	760	162.7	42.6
950	38	750	30	4	200	80	60	7.1	5	760	180.8	50.7
1000	40	800	32	4	200	80	60	6.7	5	760	200.4	52.5
1050	42	800	32	4	200	80	60	6.4	5	760	223.4	55.5
1100	44	800	32	4	200	80	60	6.1	5	760	234.1	59.3
1150	46	800	32	4	200	80	60	5.9	5	760	240.3	62.1
1200	48	800	32	4	200	80	60	5.6	5	760	270.8	66.2
1250	50	800	32	4	200	80	60	5.4	5	760	281.4	67.9
1300	52	800	32	4	200	80	60	5.2	5	760	293.3	73.6
1350	54	800	32	4	200	80	60	5.0	5	760	308.6	75.3
1400	56	950	38	4	200	80	60	4.8	5	760	372.6	83.9
1450	58	950	38	4	200	80	60	4.7	5	760	386.5	89.7
1500	60	950	38	4	200	80	60	4.5	5	760	398.4	89.9

- Weights of expansion joint and retaining ring set are based on Kurbo standard construction with ANSI 150 lbs flange drilling and may vary with selection of rubber/steel material and amount of reinforcements.
- Larger sizes up to DN3600 available upon request
- All flange drilling available with different length
- Higher pressure rating and greater movements are available upon request
- Movements shown are non-concurrent movements.

## Type 22GB-3 For 300mm Lateral Deflection

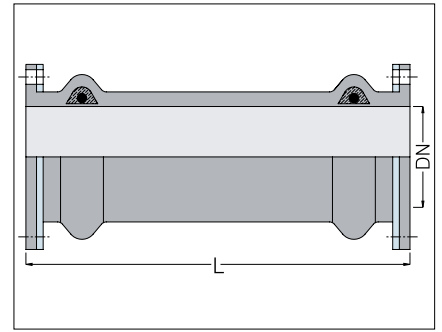

### Movement and Pressure Capability

Normal Size		Min. Length		No. of Arch	Movement Capability				Max. Pressure (bar)	Vacuum Rating (mmHg)
DN	inch	mm	inch		Lateral (mm)	Comp. (mm)	Ext. (mm)	Ang. (deg.)		
25	1	700	28	2	300	40	30	67.1	10	760
32	1.25	700	28	2	300	40	30	62.1	10	760
40	1.5	700	28	2	300	40	30	57.6	10	760
50	2	700	28	2	300	40	30	49.7	10	760
65	2.5	800	32	2	300	40	30	43.4	10	760
80	3	800	32	2	300	40	30	38.2	10	760
100	4	800	32	2	300	40	30	30.6	10	760
125	5	900	36	2	300	40	30	25.3	10	760
150	6	900	36	2	300	40	30	21.5	10	760
200	8	1000	40	2	300	40	30	16.5	10	760
250	10	1000	40	2	300	40	30	13.3	10	760
300	12	1100	44	2	300	40	30	11.1	10	760

1. Larger sizes not shown above are available upon request

## Type 22GB-4 For 400mm Lateral Deflection

### Movement and Pressure Capability

Normal Size		Min. Length		No. of Arch	Movement Capability				Max. Pressure (bar)	Vacuum Rating (mmHg)
DN	inch	mm	inch		Lateral (mm)	Comp. (mm)	Ext. (mm)	Ang. (deg.)		
25	1	1000	40	2	400	40	30	67.1	10	760
32	1.25	1000	40	2	400	40	30	62.1	10	760
40	1.5	1000	40	2	400	40	30	57.6	10	760
50	2	1100	44	2	400	40	30	49.7	10	760
65	2.5	1100	44	2	400	40	30	43.4	10	760
80	3	1100	44	2	400	40	30	38.2	10	760
100	4	1200	48	2	400	40	30	30.6	10	760
125	5	1200	48	2	400	40	30	25.3	10	760
150	6	1200	48	2	400	40	35	24.7	10	760
200	8	1300	52	2	400	40	35	19.0	10	760
250	10	1400	56	2	400	40	35	15.4	10	760
300	12	1400	56	2	400	40	35	12.9	10	760

1. Larger sizes not shown above are available upon request

## Type 23UG-PL & 24UG-PL For Connection to Plastic Piping

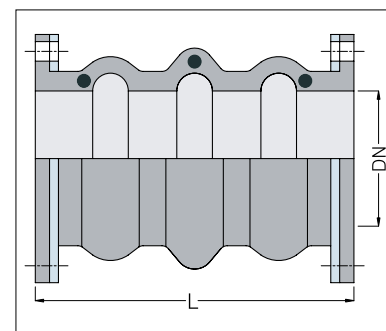

### Movement and Pressure Capability

Nominal Size		23UG-PL				24UG-PL				Max. Pressure (bar)	Vacuum Rating (mmHg)
		100mm Lateral Deflection (mm)				200mm Lateral Deflection (mm)					
DN	inch	L	comp.	Ext.	Ang.	L	comp.	Ext.	Ang.		
25	1	350	60	40	72.4	450	70	50	75.7	5	760
32	1.25	350	60	40	68.4	450	70	50	72.4	5	760
40	1.5	350	60	40	64.5	450	70	50	69.1	5	760
50	2	350	60	40	57.6	450	70	50	63.1	5	760
65	2.5	350	60	40	51.6	450	70	50	57.6	5	760
80	3	350	60	40	46.4	450	70	50	52.7	5	760
100	4	350	60	40	38.2	450	70	50	44.5	5	760
125	5	350	60	40	32.2	450	70	50	38.2	5	760
150	6	500	60	40	27.7	600	70	50	33.3	5	760
200	8	500	60	40	21.5	600	70	50	26.2	5	760
250	10	500	60	40	17.5	600	70	50	21.5	5	760
300	12	550	60	40	14.7	650	70	50	18.2	5	760
350	14	550	70	50	15.7	650	80	60	18.6	5	760
400	16	550	70	50	13.8	650	80	60	16.5	5	760
450	18	550	70	50	12.3	650	80	60	14.7	5	760
500	20	550	70	50	11.1	650	80	60	13.3	5	760
550	22	550	70	50	10.1	650	80	60	12.1	5	760
600	24	550	70	50	9.3	650	80	60	11.1	5	760
650	26	650	70	50	8.6	750	80	60	10.3	5	760
700	28	650	70	50	8.0	750	80	60	9.6	5	760
750	30	650	70	50	7.5	750	80	60	8.9	5	760
800	32	650	70	50	7.0	750	80	60	8.4	5	760
850	34	650	70	50	6.6	750	80	60	7.9	5	760
900	36	650	70	50	6.2	750	80	60	7.5	5	760
950	38	650	70	50	5.9	750	80	60	7.1	5	760
1000	40	700	70	50	5.6	800	80	60	6.7	5	760
1050	42	700	70	50	5.4	800	80	60	6.4	5	760
1100	44	700	70	50	5.1	800	80	60	6.1	5	760
1150	46	700	70	50	4.9	800	80	60	5.9	5	760
1200	48	700	70	50	4.7	800	80	60	5.6	5	760
1250	50	700	70	50	4.5	800	80	60	5.4	5	760
1300	52	700	70	50	4.3	800	80	60	5.2	5	760
1350	54	700	70	50	4.2	800	80	60	5.0	5	760
1400	56	750	70	50	4.0	950	80	60	4.8	5	760
1450	58	750	70	50	3.9	950	80	60	4.7	5	760
1500	60	750	70	50	3.8	950	80	60	4.5	5	760

1. All flange drilling available with different length
2. Higher pressure rating is available upon request
3. Movements shown are non-concurrent movements.

## Type 21EP Externally Pressurized Joint



### Submerged Application

When expansion joint piping system is submerged in water and the medium is conveyed through the pipe line, the expansion joint is subject to internal and external pressures as arch element is externally pressurized. Therefore, the joint in this pipe line must be engineered and designed to withstand external pressure as well as internal one and also to be suitable for vacuum service.

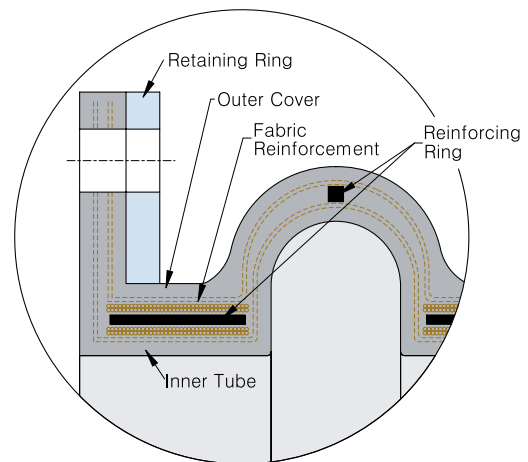

### Construction

#### Tube

- Seamless, smooth construction of a tube rubber extends through the bore to the outer edge of both flanges.
- Extra thick tube to yield superior performance in harsh conditions.

#### Reinforcements

- Totally impregnated high strength calendered polyester fabric.
- Heavy duty construction of metal rings : rectangular body rings or solid annular rings bonded into carcass and round or square arch support ring encapsulated with rubber inside the arch.

#### Cover

- Homogeneous leak tight multi-layers of rubber to prevent the water from attacking the carcass.
- Extra thick elastomeric cover to protect the body materials from external pressure conditions.
- Standard material is Neoprene tube and cover with SS 316 retaining rings.  
Other elastomers and steel materials are available.

#### Features

- **Greater strength and higher pressure rating** : The heavy duty metal reinforcing rings embedded in the carcass and arch provide additional hoop strength, increasing the ability to withstand higher external and internal pressure rating. All sizes up to DN1800 are designed to withstand external pressure produced in 50 meters depth of seawater/water.
- **Fully engineered and field proven** : All type 21EP have been engineered and tested in factory to ensure long life time and reliable service. They are unmatched design proven by piping designers, pressure vessel designers and consulting engineers.
- **Bolt hole lining** : Totally rubber lined bolt holes prevent water from penetrating into the carcass through the holes and protect fabric and metal reinforcements in carcass, resulting in longer service life and durability.

**Pressure Rating and Movement Capability**

Nominal Size		Minimum Length		Max. Pressure		Vacuum Rating (mmHg)	Movement Capability			
				Internal (bar)	External (bar)		Comp. (mm)	Ext. (mm)	Lat. (mm)	Ang. (deg.)
DN	inch	mm	inch							
50	2	150	6	15	10	760	20	15	12	30.6
65	2.5	150	6	15	10	760	20	15	12	25.3
80	3	150	6	15	10	760	20	15	12	21.5
100	4	150	6	15	10	760	20	15	12	16.5
125	5	150	6	15	10	760	20	15	12	13.3
150	6	150	6	15	10	760	25	20	12	14.7
200	8	150	6	10	10	760	25	20	12	11.1
250	10	200	8	10	10	760	25	20	12	8.9
300	12	200	8	10	10	760	25	20	16	7.5
350	14	200	8	10	10	760	25	20	16	6.4
400	16	200	8	10	10	760	25	20	16	5.6
450	18	200	8	10	10	760	25	20	16	5.0
500	20	200	8	10	10	760	25	20	16	4.5
550	22	250	10	10	10	760	30	25	18	5.1
600	24	250	10	10	10	760	30	25	18	4.7
650	26	250	10	8	8	760	30	25	18	4.3
700	28	250	10	8	8	760	30	25	18	4.0
750	30	250	10	8	8	760	30	25	18	3.8
800	32	250	10	8	8	760	30	25	18	3.5
850	34	250	10	8	8	760	30	25	18	3.3
900	36	250	10	6	6	760	30	25	18	3.1
950	38	250	10	6	6	760	30	25	18	3.0
1000	40	250	10	6	6	760	30	25	18	2.8
1050	42	300	12	6	6	760	35	25	20	2.7
1100	44	300	12	6	6	760	35	25	20	2.6
1150	46	300	12	6	6	760	35	25	20	2.5
1200	48	300	12	6	6	760	35	25	20	2.3
1250	50	300	12	6	5	760	35	25	20	2.3
1300	52	300	12	6	5	760	35	25	20	2.2
1350	54	300	12	6	5	760	35	25	20	2.1
1400	56	300	12	6	5	760	35	25	20	2.0
1450	58	300	12	6	5	760	35	25	20	1.9
1500	60	300	12	6	5	760	35	25	20	1.9
1650	66	300	12	6	5	760	35	25	20	1.7
1800	72	300	12	6	5	760	35	25	20	1.6

1. Multiple arch design is available

2. Contact Kurbo for additional information such as other sizes, lengths and pressures not listed.

## Type 21DM Demounting Joint



### Application

Kurbo Type 21DM, Demounting joints provide axial clearance in the piping system to allow for easy and quick removal or replacement of the pipe component and equipment. It is simply done by compressing the 21DM—demounting joint with its threaded tie rods. The 21DM makes it possible for worker to complete maintenance quickly. In general, removal and assembly of pipe component or equipment for maintenance require lots of time and cost.

We recommend that you include our Type 21DM demounting joint alongside each of these critical components and equipment like valves, shut off gates and pumps etc in the piping considering the maintenance convenience later on.

### Feature and Advantage

- Easier and quicker dismantling and replacing components—Maintenance costs and time will be reduced
- Reduced down time and loss of production.
- Weighs a lot less than the demounting joint made of steel—Less handling and installation cost
- L-shaped integral flange help compress the rubber bellows with less force.
- Greater strength and Higher pressure rating : Unique arrangement of spring steel wire and combined construction of bias/radial tire cord increases pressure/vacuum capability : 4 to 1 safety factor for all sizes up to DN2400.
- Greater flexibility : Wide arch profile and fabric angle adjustment provides great flexibility and increased all directional movement capability
- The 21DM made of elastomer offers no noise and vibration transfer to the mating flanges on pipe or equipment side.
- Wide spectrum of elastomers available—Natural rubber, Neoprene, Chlorobutyl, Nitrile, EPDM, CSM, Viton and other special grade rubber for individual piping system
- Flanged design : No gasket required due to seamless rubber flange face.
- The 21DM with turn buckles available

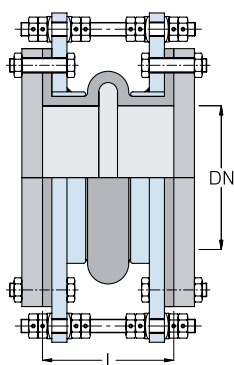

### Movement and Pressure Rating

Nominal Size		Minimum Length		Movement Capability				Max. Pressure (bar)	Vacuum Rating (mmHg)
DN	inch	mm	inch	Comp. (mm)	Ext. (mm)	Lat. (mm)	Ang. (deg.)		
150	6	200	8	40	20	12	14.7	10	710
200	8	200	8	40	20	12	11.1	10	710
250	10	200	8	40	20	12	8.9	10	710
300	12	250	10	40	20	12	7.5	10	710
350	14	250	10	40	20	12	6.4	10	710
400	16	250	10	40	20	12	5.6	8	710
450	18	250	10	40	20	12	5.0	8	710
500	20	250	10	40	20	12	4.5	8	710
550	22	250	10	40	20	12	4.1	8	710
600	24	250	10	50	25	12	4.7	8	710
650	26	250	10	50	25	12	4.3	7	710
700	28	250	10	50	25	12	4.0	7	710
750	30	250	10	50	25	12	3.8	7	710
800	32	300	12	50	25	12	3.5	7	710
850	34	300	12	50	25	12	3.3	7	710
900	36	300	12	50	25	12	3.1	7	710
950	38	300	12	50	25	12	3.0	7	710
1000	40	300	12	50	25	12	2.8	7	710
1050	42	300	12	50	25	12	2.7	6	710
1100	44	300	12	50	25	12	2.6	6	710
1150	46	300	12	50	25	12	2.5	6	710
1200	48	300	12	50	25	12	2.3	6	710
1250	50	300	12	50	25	12	2.3	6	660
1300	52	350	14	50	25	12	2.2	6	660
1350	54	350	14	50	25	12	2.1	6	660
1400	56	350	14	50	25	12	2.0	6	660
1450	58	350	14	50	25	12	1.9	6	660
1500	60	350	14	50	25	12	1.9	6	660
1650	66	350	14	50	25	12	1.7	6	660
1800	72	350	14	50	25	12	1.6	5	660
1950	78	350	14	50	25	12	1.4	5	660
2100	84	350	14	50	25	12	1.3	5	660
2250	90	350	14	50	25	12	1.3	4	660
2400	96	350	14	50	25	12	1.2	4	660

1. All flange drilling available.
2. Contact Kurbo for additional information such as other sizes, lengths and pressures not listed.



## Type 21FL Flowing Arch Type Joint



### *No needs for filled arches on slurry services.*

Kurbo Type 21FL expansion joints utilize wide flowing arch and can easily replace and interchange with filled arches and molded spherical expansion joints. The 21FL expansion joints have been widely used in major industries including HVAC, chemical, petrochemical, marine, power plants, pulp & paper, process piping systems, water/waste water treatment and steel mill.

### Features

- The "flowing arch" is self-flushing which prevents media buildup and reduces fluid turbulence, thus eliminates the requirement for a filled arch joint.
- Increased movement : The flowing arch design provides more movement in comparison to narrow or filled arch spool type joints.
- 30% increased compression movement and 45% reduced spring rates compared to the Kurbo Type F21W-filled wide arch design
- Exclusive construction with no metal reinforcing rings or wires while providing higher pressure and vacuum ratings.
- The 21FL weighs up to 30–40% less compared to filled arch type joint—Lightweight design installs easily and costs less to ship
- Minimize water hammer and hydraulic shock
- Available in a wide variety of tube and cover elastomers, including natural, butyl, neoprene, nitrile, CSM, EPDM and viton.
- All Kurbo Type 21FL expansion joints have been in–factory and field tested to ensure long life and reliable field service.

### Performance Comparison - Spring Rate and Pressure Test Results

Size (DN X L)	Company (Competitor)	Spring Rate at zero pressure (kg/mm)			Burst Pressure (bar)	Vacuum at 12mm Axial Extension (mmHg)
		Comp.	Ext.	Lat.		
150 X 150	Competitor - A	24.9	32.9	25.8	30	660
	Competitor - B	32.2	21.7	18.8	42	660
	Kurbo 21FL	18.7	19.8	17.1	52	700
300 X 200	Competitor - A	27.5	39.5	47.2	20	600
	Competitor - B	36.3	34.3	27.4	38	350
	Kurbo 21FL	29.6	29.1	26.2	45	700

1. Test Results above show that Kurbo Type 21FL have lower spring rates than other competitors' products while offering higher burst pressure and vacuum resistance

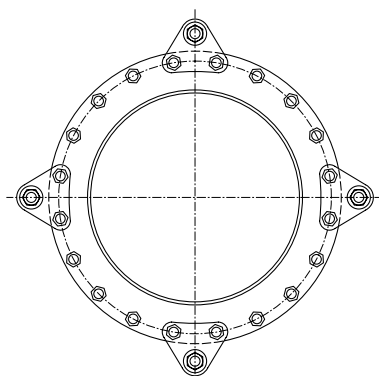
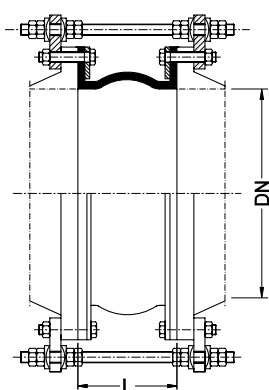

**Movement · Pressure · Weight**

Nominal Size		Face to Face Length		Movement Capability				Max. Pressure (bar)	Vacuum Rating (mmHg)	Weights (kg)		
DN	inch	mm	inch	Comp. (mm)	Ext. (mm)	Lat. (mm)	Ang. (deg.)			Exp Joint	Retaining Ring Set	Control Rod Set (1)
50	2	150	6	25	12	12	25.3	13	720	0.7	1.7	2.2
65	2.5	150	6	25	12	12	20.7	13	720	0.9	2.5	2.4
80	3	150	6	25	12	12	17.5	13	720	1.0	2.7	2.5
100	4	150	6	25	12	12	13.3	13	720	1.4	3.8	2.0
125	5	150	6	25	12	12	10.7	13	720	1.7	4.0	2.2
150	6	150	6	25	12	12	8.9	13	720	2.0	4.6	2.6
200	8	150	6	25	12	12	6.7	10	720	2.8	6.7	3.8
250	10	200	8	30	12	12	5.4	10	720	4.7	8.7	5.5
300	12	200	8	30	12	12	4.5	10	720	7.4	12.3	6.9
350	14	200	8	30	12	12	3.9	8	660	8.4	13.5	7.6
400	16	200	8	30	12	12	3.4	8	660	9.9	16.6	8.5
450	18	200	8	30	12	12	3.0	8	660	10.4	16.0	9.0
500	20	200	8	30	12	12	2.7	8	660	12.0	19.3	8.7
550	22	250	10	30	12	12	2.5	7	660	17.1	19.5	12.9
600	24	250	10	30	12	12	2.3	7	660	19.4	23.9	13.4
650	26	250	10	30	12	12	2.1	6	660	21.2	26.4	13.1
700	28	250	10	30	12	12	1.9	6	660	23.0	29.2	16.4
750	30	250	10	30	12	12	1.8	6	450	25.0	32.7	19.2
800	32	250	10	30	12	12	1.7	6	450	30.3	38.4	20.9
850	34	250	10	30	12	12	1.6	6	450	31.9	39.9	24.0
900	36	250	10	30	12	12	1.5	6	450	34.3	44.0	25.9
950	38	250	10	30	12	12	1.4	6	450	37.9	52.2	26.5
1000	40	250	10	30	12	12	1.4	6	450	39.6	54.1	23.4
1050	42	300	12	35	15	12	1.3	5	380	48.6	57.1	25.6
1100	44	300	12	35	15	12	1.2	5	380	51.3	61.1	25.3
1150	46	300	12	35	15	12	1.2	5	380	53.6	63.9	25.6
1200	48	300	12	35	15	12	1.1	5	380	56.3	68.1	28.5

1. Pressure rating is based on 70°C. At lower operating temperatures, ratings will increase.
2. Pressure and vacuum ratings are for standard "face to face" length only. Contact Kurbo for other longer length.
3. The 21FL with higher pressure and vacuum ratings are available upon request.
4. For additional information such as other sizes, lengths and pressures not listed, contact Kurbo.

## Type 21M Molded Type Expansion Joint



### Features

- Molded extra wide arch expansion joints Type 21M combine the best design features of spool and spherical type joint and produce exceptional performance value.
- The Type 21M utilize low wide arch profile and provide more than twice movement capability of spool type joint. Thus, they eliminate the needs for double arch spool type joint resulting in less cost.
- The unique construction of molded rubber reinforced with the fabric/steel ring provides much lower spring rate.
- Full vacuum rating for all sizes

### Dimensions

- All face to face dimensions in sizes from DN50 to DN300 are standard due to the molded construction.
- For design variations including non-standard face to face length, multi-arch configuration, special flange drilling etc, Kurbo provides Series 20W, hand made version of Type 21M.

### Pressure

Type 21M is engineered to withstand high pressure and full vacuum rating utilizing high tensile synthetic fabric and solid steel rings embedded at each side of arch.

### Elastomers

Various elastomers are available—Pure Gum Rubber, Neoprene, Chlorobutyl, Nitrile, EPDM, CSM, Viton and other Food grade rubber

### Dimension · Movement · Pressure · Weight

Nominal Size		Standard Length		Dimensions			Max. Press.	Movement Capability				Weights (kg)		
DN	inch	mm	inch	O.D. (mm)	B.C. (mm)	Hole (No.-Dia.)	(bar)	Comp. (mm)	Ext. (mm)	Lat. (mm)	Ang. (deg.)	Exp Joint	Retaining Ring Set	1 Control Rod Set
50	2	150	6	152	120.7	4-19	15	40	18	18	35.3	1.3	1.4	1.4
65	2.5	150	6	178	139.7	4-19	15	40	18	18	29.6	1.5	2.0	1.7
80	3	150	6	190	152.4	4-19	15	40	18	18	25.3	1.7	2.2	1.7
100	4	150	6	229	190.5	8-19	15	40	18	18	19.5	2.5	2.9	1.9
125	5	150	6	254	215.9	8-22	15	40	18	18	15.8	3.2	3.3	2.2
150	6	150	6	279	241.3	8-22	10	40	18	22	13.3	3.5	3.6	2.2
200	8	150	6	343	298.5	8-22	10	40	18	22	10.0	4.6	5.5	3.6
250	10	200	8	406	362.0	12-25	10	45	20	25	8.9	8.5	6.7	5.6
300	12	200	8	483	431.8	12-25	10	45	20	25	7.5	11.9	9.9	5.6

1. Movements are non-concurrent

2. Pressure ratings are based on 70°C operating temperature. Minimum burst pressure is 4 to 1

3. Dimensions shown are in accordance with ANSI 125/150 lbs standard

## Type 21TL PTFE Lined Expansion Joint

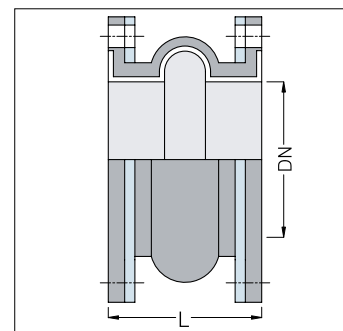
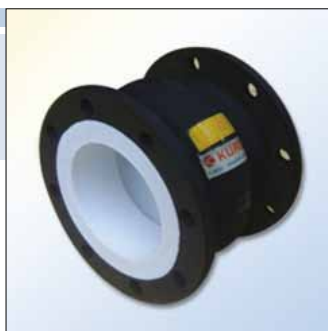

### Application

Kurbo PTFE lined expansion joints are ideal for severe service conditions in chemical plants, paper mills, pollution control system and other piping systems where highly corrosive chemicals and acids are conveyed. They are also suitable for high temperature and high pressure applications.

### Features

- Combination of best features of PTFE and rubber expansion joint : PTFE liner has excellent chemical and heat resistance and rubber joint has high pressure rating, good noise and vibration absorption. Thus PTFE lined expansion joints provide superior chemical resistance even at high temperatures and high pressures.
- The joint body that is bonded to a PTFE liner is reinforced with high tensile synthetic fiber and steel wire. Thus PTFE lined joints have much higher pressure capability than PTFE expansion joints/bellows.
- PTFE liner is non-contaminating and suits a wide range of applications
- High density PTFE liner offers optimal chemical resistance and permeation reduction
- Excellent thermal stability—temperature ratings to 200°C
- Extraordinary all directional movement capability

### Pressure and Movement Capability

Nominal Size		Standard Length		Max. Pressure (bar)	Vacuum Rating (mmHg)	Movement Capability			
DN	inch	mm	inch			Comp. (mm)	Ext. (mm)	Lat. (mm)	Ang. (deg.)
50	2	150	6	12	710	20	10	12	10.0
65	2.5	150	6	12	710	20	10	12	10.0
80	3	150	6	12	710	20	10	12	10.0
100	4	150	6	12	710	20	10	12	10.0
125	5	150	6	12	710	25	12	12	10.0
150	6	150	6	12	710	25	12	12	8.9
200	8	150	6	10	710	25	12	12	6.7
250	10	200	8	10	710	25	12	12	5.4
300	12	200	8	10	710	30	15	15	5.6
350	14	200	8	10	710	30	15	15	4.8
400	16	200	8	8	710	30	15	15	4.2
450	18	200	8	8	710	30	15	15	3.8
500	20	200	8	8	710	30	15	15	3.4
550	22	250	10	8	710	35	17	15	3.5
600	24	250	10	8	710	35	17	15	3.2
650	26	250	10	7	710	35	17	15	2.9
700	28	250	10	7	710	35	17	15	2.7
750	30	250	10	7	710	35	17	15	2.6
800	32	250	10	7	710	35	17	15	2.4
850	34	250	10	7	710	35	17	15	2.3
900	36	250	10	7	710	35	17	15	2.1
950	38	250	10	7	710	35	17	15	2.0
1000	40	250	10	7	710	35	17	15	1.9

1. Multiple arch design is available against quantity

2. Contact Kurbo for additional information such as other sizes, lengths and pressures not listed.

## Type 21CR / 21ER Reducer Joint



Kurbo Reducing expansion joints are used to connect different diameter pipes. These tapered joints act as flexible connectors and vibration dampeners for absorption of pipe stress, movements and noise/vibration.

We offer 2 types of reducing joints—Concentric and Eccentric shapes.

Type 21CR is Concentric reducers with the axis of each end concentric with each other. Each flange—end shares the same common center line. Type 21ER is Eccentric reducers having the axis of each end offset from each other.

All flange drilling with straddle center line unless otherwise specified.

### Features

- Versatile hand—built construction
- Available in concentric, eccentric or custom—made offset arrangement
- Available in multiarch, filled arch, without arch, sleeve ends
- Wide and low arch profile offers 2 times greater movement capability than other competitors' conventional product
- Available in a wide variety of sizes

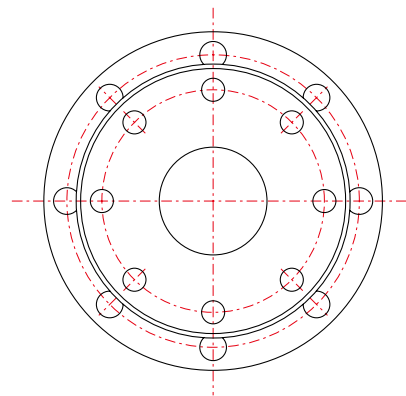
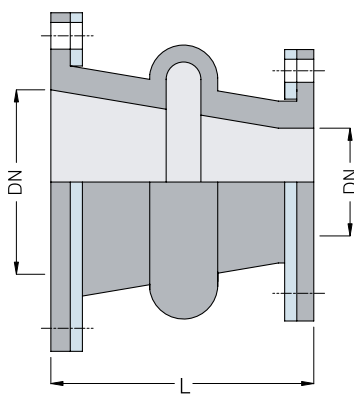

21CR : Concentric Reducer Expansion Joint

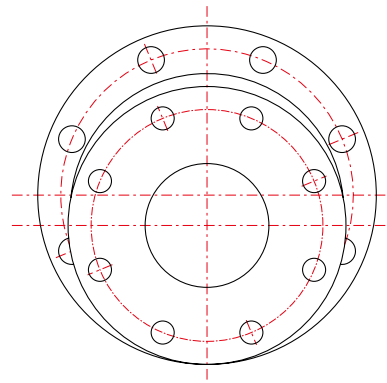
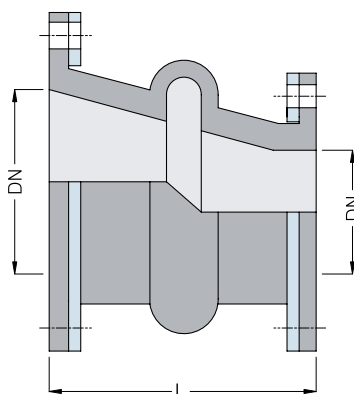

21ER : Eccentric Reducer Expansion Joint



21CR



21ER

**Movement · Pressure · Weight**

Nominal Size	Length-(L) mm		Movement Capability				Max. Pressure (bar)	Vacuum Rating (mmHg)	Weights (kg)					
			Comp. (mm)	Ext. (mm)	Lat. (mm)	Ang. (deg.)			21CR			21ER		
	DN x DN	21CR							21ER	Exp Joint	Retaining Ring set	1 Control Rod Set	Exp Joint	Retaining Ring set
50 x 25	200	200	20	10	12	25	10	660	0.9	1.2	2.7	0.9	1.2	3.3
50 x 40	200	200	20	10	12	25	10	660	1.0	1.4	2.7	1.0	1.4	3.3
65 x 40	200	200	20	10	12	20	10	660	1.3	1.7	3.2	1.3	1.7	3.6
65 x 50	200	200	20	10	12	20	10	660	1.5	1.9	3.2	1.5	1.9	3.9
80 x 25	200	200	30	15	12	24	10	660	1.5	1.6	3.4	1.5	1.6	4.1
80 x 40	200	200	30	15	12	24	10	660	1.6	1.8	3.4	1.6	1.8	4.1
80 x 50	200	200	30	15	12	24	10	660	1.7	2.0	3.4	1.7	2.0	4.1
80 x 65	200	200	30	15	12	24	10	660	1.8	2.3	3.4	1.8	2.3	4.1
100 x 50	200	200	30	15	12	18	10	660	2.1	2.5	3.4	2.1	2.5	4.1
100 x 65	200	200	30	15	12	18	10	660	2.3	2.8	3.6	2.3	2.8	4.1
100 x 80	200	200	30	15	12	18	10	660	2.8	2.9	3.6	2.8	2.9	4.1
125 x 80	200	200	35	17	12	17	10	660	3.0	3.0	4.5	2.9	3.0	4.3
125 x 100	200	200	35	17	12	17	10	660	3.1	3.5	4.3	3.3	3.5	4.5
150 x 50	200	200	35	17	12	14	10	660	3.1	2.8	5.4	3.2	2.8	6.8
150 x 65	200	200	35	17	12	14	10	660	3.2	3.1	5.9	3.3	3.1	6.4
150 x 80	200	200	35	17	12	14	10	660	3.3	3.2	5.9	3.3	3.2	5.9
150 x 100	200	200	35	17	12	14	10	660	3.6	3.7	5.0	3.7	3.7	5.1
150 x 125	200	200	35	17	12	14	10	660	3.8	3.8	5.4	3.8	3.8	5.1
200 x 80	200	200	35	17	12	11	10	660	4.4	4.2	9.3	5.5	4.2	9.1
200 x 100	200	200	35	17	12	11	10	660	4.6	4.7	9.1	5.8	4.7	8.6
200 x 125	200	200	35	17	12	11	10	660	4.8	4.8	8.6	5.9	4.8	8.4
200 x 150	200	200	35	17	12	11	10	660	5.1	5.0	8.2	6.1	5.0	8.2
250 x 125	250	250	35	17	12	8	10	660	6.6	5.7	10.9	6.4	5.7	10.9
250 x 150	250	250	35	17	12	8	10	660	7.1	5.9	11.3	7.6	5.9	11.8
250 x 200	250	250	35	17	12	8	10	660	7.8	6.9	12.2	8.1	6.9	11.3
300 x 150	250	300	35	17	12	7	10	660	9.2	7.7	13.6	10.4	7.7	12.7
300 x 200	250	250	35	17	12	7	10	660	10.1	8.7	13.6	10.7	8.7	10.9
300 x 250	250	250	35	17	12	7	10	660	11.0	9.6	11.3	11.8	9.6	11.3
350 x 200	250	300	35	17	12	6	7	660	12.4	9.3	13.6	14.4	9.3	14.7
350 x 250	250	300	35	17	12	6	7	660	13.1	10.2	13.6	15.4	10.2	13.8
350 x 300	250	250	35	17	12	6	7	660	15.0	12.0	12.2	17.0	12.0	13.2
400 x 250	250	300	35	17	12	5	7	660	15.2	11.3	17.2	18.1	11.3	18.6
400 x 300	250	300	35	17	12	5	7	660	15.9	13.1	17.2	18.3	13.1	17.0
400 x 350	250	250	35	17	12	5	7	660	16.6	13.7	15.9	19.1	13.7	15.0
450 x 300	250	300	35	17	12	5	7	660	17.1	13.7	17.7	19.1	13.7	18.1
450 x 350	250	300	35	17	12	5	7	660	17.8	14.3	17.7	19.7	14.3	17.5
450 x 400	250	250	35	17	12	5	7	660	18.5	15.4	16.3	19.8	15.4	16.8
500 x 350	250	300	35	17	12	4	7	660	19.2	15.3	18.6	21.5	15.3	18.7
500 x 400	250	300	35	17	12	4	7	660	20.1	16.4	19.1	22.2	16.4	19.3
500 x 450	250	250	35	17	12	4	7	660	21.6	17.0	17.7	22.5	17.0	17.4

• Both concentric and eccentric reducers with shorter face to face length are available. For details, contact Kurbo.

## Control Units with Rubber Flanged Expansion Joint



### Control Units

Control units are designed to minimize possible failure of the expansion joint from excessive motions caused by failure of anchoring/guiding, abnormal thermal fluctuation and pressure surge etc. Control unit assemblies can be set at the maximum allowable extension and compression of rubber expansion joint and absorb static pressure thrust developed at the expansion joint. When used in this manner, control units are additional safety factor and can minimize possible damage to adjacent equipment.

### Use of Control Units

Rubber expansion joints must be installed between two fixed anchor points in piping and piping anchors must take end thrusts produced by internal pressure or thermal changes. When it is impossible to provide adequate anchors, control units must be used to restrain the piping system

*Kurbo supplies various control unit configurations for individual piping system as shown below.*

#### GP : Gusset Plate with control rod

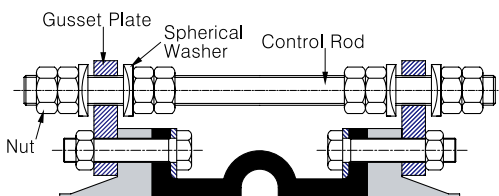

#### IF : Integral Flange with control rod

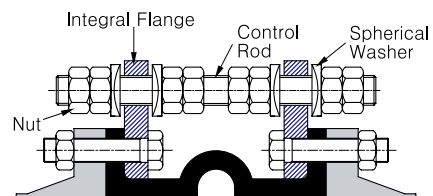

#### HG-I : Hinge with integral gusset

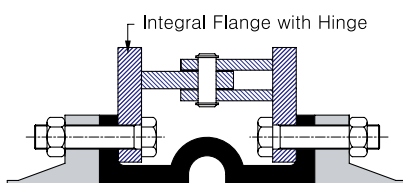

#### HG-S : Hinge with separate gusset

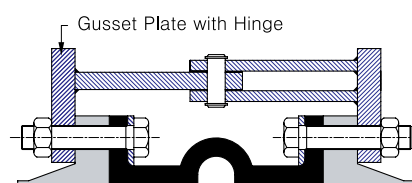

### Features

- Protect expansion joints from over-extension and over-compression
- Galvanized carbon steel rods are standard. Stainless steel and other materials available as material selection varies with environmental conditions
- Optional internal nuts or compression sleeves available : To prevent over-compression. Double nuts are recommended for field adjustment and compression sleeve shall be field trimmed
- Available with rubber washers/grommets : To isolate vibration.
- Available with spherical washers : To prevent binding during offset.
- Available with hinges with integral gusset or separate gusset : To allow for angular movement in one plane.
- Gimbals available : To allow for angular movement in two directions.
- Available with integral flange : To provide equal distribution of forces and prevent stress concentration. Also to prevent any transmission of noise and vibration to mating flange.

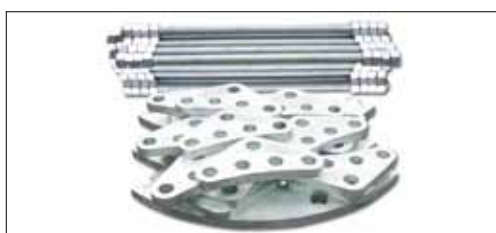

HG-S



### Kurbo Control Unit Dimensions and Rating

Nominal Pipe Size		Dimensions (mm)			Number of Control Rod Required				
		Plate O.D.	Plate Thick.	Dia. Rod	Max. Pressure of System-bar				
DN	inch				2	3	4	6	8
25	1	184	10	M12	78.7				
32	1.25	195	10	M12	65.4				
40	1.5	203	10	M12	55.2				
50	2	241	10	M16	59.8				
65	2.5	269	10	M16	47.2				
80	3	279	10	M16	38.1				
100	4	318	10	M16	26.4	39.7	52.9		
125	5	343	10	M16	17.4	26.1	34.7		
150	6	369	12	M16	13.5	20.2	26.9		
200	8	447	12	M20	14.1	21.2	28.2		
250	10	518	19	M22	12.2	18.3	24.4	36.6	
300	12	607	19	M24	10.2	15.3	20.4	30.5	
350	14	658	19	M24	7.9	11.8	15.8	23.7	
400	16	734	19	M27	8.0	12.0	15.9	23.9	31.9
450	18	771	19	M27	6.5	9.8	13.0	19.5	26.0
500	20	835	19	M27	5.4	8.1	10.8	16.3	21.7
550	22	897	25	M30	5.5	8.2	11.0	16.4	21.9
600	24	962	25	M30	4.7	7.0	9.4	14.1	18.8
650	26	1017	25	M30	4.1	6.1	8.2	12.2	16.3
700	28	1085	32	M33	4.4	6.6	8.8	13.3	17.7
750	30	1154	32	M36	4.6	6.9	9.1	13.7	18.3
800	32	1230	32	M36	4.1	6.1	8.1	12.2	16.3
850	34	1292	38	M39	4.4	6.6	8.8	13.1	17.5
900	36	1363	38	M39	3.9	5.9	7.9	11.8	15.8
950	38	1431	38	M39	3.6	5.3	7.1	10.7	14.3
1000	40	1459	38	M39		4.9	6.5	9.7	13.0
1050	42	1528	38	M39		4.3	5.7	8.6	11.4
1100	44	1586	38	M39		3.9	5.3	7.9	10.5
1150	46	1637	38	M39		3.6	4.8	7.3	9.7
1200	48	1704	38	M42		3.9	5.2	7.8	10.4
1250	50	1762	38	M42		3.6	4.8	7.2	9.6
1300	52	1819	38	M42		3.4	4.5	6.7	9.0
1350	54	1904	38	M48		4.0	5.3	8.0	10.6
1400	56	1965	38	M48		3.7	5.0	7.4	9.9
1450	58	2022	38	M48		3.5	4.7	7.0	9.3
1500	60	2074	45	M48		3.3	4.4	6.6	8.7
1550	62	2137	45	M48			4.1	6.2	8.2
1650	66	2252	50	M48			3.7	5.5	7.3
1800	72	2417	50	M48			3.1	4.7	6.2
1950	78	2611	50	M56			3.7	5.6	7.4
2100	84	2783	55	M56			3.2	4.9	6.5
2250	90	2979	65	M64			3.7	5.5	7.4
2400	96	3165	65	M68			3.8	5.7	7.5
2550	102	3336	65	M68			3.4	5.0	6.7
2700	108	3506	65	M68			3.0	4.5	6.0
2850	114	3686	65	M68			2.7	4.1	5.4
3000	120	3849	65	M68			2.5	3.7	4.9
3300	132	4205	65	M68			2.1	3.1	4.1
3600	144	4523	65	M68			1.7	2.6	3.5

**WARNING :** Control Units must be used to protect expansion joints from excessive movements if piping is not properly anchored. Expansion joint may operate in pipelines or equipment carrying fluid and/or gases at elevated temperatures and pressures, so precaution should be taken to make sure these parts are installed and inspected regularly. Care is required to protect personnel in the event of leakage or splash.

- The values are based on mild steel material and 65% of yield strength of the Rod. Number of rods are depending upon maximum test pressure. Dimensions will change when using high tensile steel. For more details and proper installation, contact Kurbo.
- Plate O.D. is based on Kurbo standard design and 150lbs standards of ANSI/ASME B16.5 Class 150, ANSI/ASME B16.47 Class 150 Series A and AWWA C207 Class D 150lbs.
- For control unit length, customer should provide flange specification or mating flange thickness.



## Type 31FF / 32FF Floating Flange Design

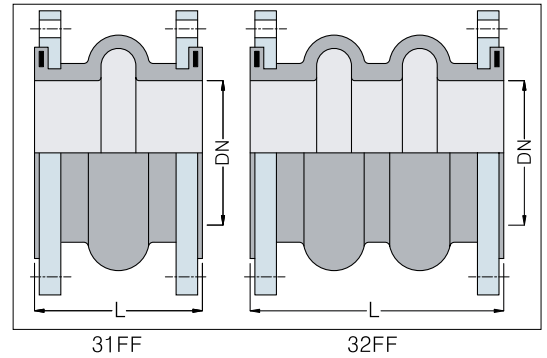
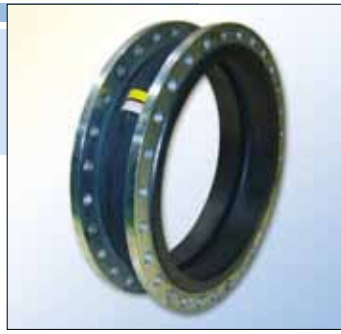

### Features

- **Greater strength** : Unique arrangement of spring steel wire and combined construction of bias/radial tire cord increases pressure/vacuum capability
- **Superior reliability and durability** : With quality materials and optimum selection of construction and professional workmanship allow Kurbo 30FF to guarantee longer service life.
- **Wide variety of elastomers** : As a standard elastomers, natural rubber, neoprene, nitrile, butyl, EPDM, CSM elastomers are available. As a special, food grade white rubber, flame resistance rubber, Viton and Teflon available.
- **Wide spectrum of fabric and metal reinforcements** : Standard fabric is high tensile polyester tire cord. Other materials like nylon, Kevlar, Nomex available. Different grade of corrosion resistant steel wire and annular ring are used in carcass for pressure/vacuum bearing reinforcement layers.
- **Steel Flange** : The flanges rotate freely on the rubber bellows compensating for mating flange misalignment—Simple and quick installation
- No retaining ring or control rod plate(gusset plate) required—Easy handling and quick installation

### Movement and Pressure Rating

Nominal Size		Min. Length				Movement Capability				Max. Pressure (bar)	Vacuum Rating (mmHg)
		31FF		32FF		Comp.	Ext.	Lat.	Ang.		
DN	inch	mm	inch	mm	inch	(mm)	(mm)	(mm)	(deg.)		
100	4	150	6	300	12	35	17	16	18.5	10	660
150	6	200	8	300	12	40	20	18	14.7	10	660
200	8	200	8	300	12	40	20	18	11.1	10	660
250	10	200	8	300	12	40	20	18	8.9	10	660
300	12	200	8	300	12	40	20	20	7.5	10	660
350	14	200	8	350	14	40	20	20	6.4	10	660
400	16	200	8	350	14	40	20	20	5.6	10	660
450	18	200	8	350	14	40	20	20	5.0	10	660
500	20	250	10	350	14	40	20	20	4.5	10	660
600	24	250	10	400	16	50	25	23	4.7	7	660
700	28	250	10	400	16	50	25	23	4.0	7	660
750	30	250	10	400	16	50	25	23	3.8	7	660
800	32	300	12	400	16	50	25	23	3.5	7	660
900	36	300	12	400	16	50	25	23	3.1	7	660
1000	40	300	12	400	16	50	25	23	2.8	5	660
1050	42	300	12	450	18	60	30	25	3.2	5	660
1100	44	300	12	450	18	60	30	25	3.1	5	660
1150	46	300	12	450	18	60	30	25	2.9	5	660
1200	48	300	12	450	18	60	30	25	2.8	5	660

1. Movements listed above are based on the Type 31FF, single open arch design. To obtain movements of Type 32FF, multiply single arch values by 2.  
2. Larger sizes not shown are available upon request.

## Type 31BF / 32BF Built-in Flange Design

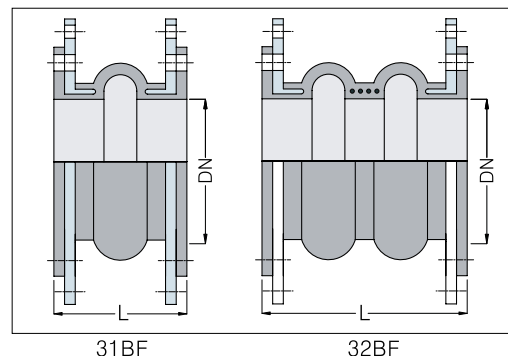
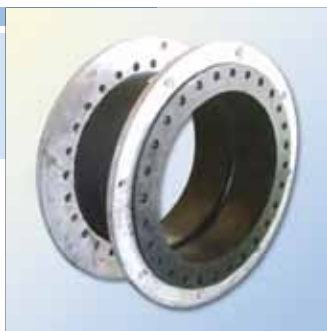

31BF

32BF

### Features

- Built-in steel flanges serve as pressure/vacuum bearing reinforcement layer, thus suitable for high pressurized pipes and vacuum service.
- Full faced rubber flange bonded to steel flanges provides tight seal
- L-shaped steel flanges are anchored in the joint body so that axial loads can be accommodated.
- Less deformation under pressure provides reduced stress on related piping system components.
- Choice of construction materials suitable for wide range of service temperatures
- Excellent chemical and abrasion resistance
- No retaining ring or control rod plate required—Easy handling and simple installation

### Movement and Pressure Rating

Nominal Size		Min. Length				Movement Capability				Max. Pressure (bar)	Vacuum Rating (mmHg)
		31BF		32BF		Comp. (mm)	Ext. (mm)	Lat. (mm)	Ang. (deg.)		
DN	inch	mm	inch	mm	inch						
100	4	200	8	300	12	30	15	15	16.5	15	760
150	6	200	8	300	12	30	15	15	11.1	15	760
200	8	200	8	300	12	30	15	15	8.4	15	760
250	10	200	8	300	12	30	15	15	6.7	15	760
300	12	200	8	300	12	30	15	15	5.6	15	760
350	14	200	8	300	12	30	15	15	4.8	10	760
400	16	250	10	350	14	30	15	15	4.2	10	760
450	18	250	10	350	14	30	15	15	3.8	10	760
500	20	250	10	350	14	30	15	15	3.4	10	760
600	24	300	12	450	18	40	20	18	3.8	10	760
700	28	300	12	450	18	40	20	18	3.2	10	760
750	30	300	12	450	18	40	20	18	3.0	10	760
800	32	300	12	450	18	40	20	18	2.8	10	760
900	36	300	12	450	18	40	20	18	2.5	10	760
1000	40	300	12	450	18	40	20	18	2.3	10	760
1050	42	350	14	500	20	40	20	18	2.1	10	760
1100	44	350	14	500	20	40	20	18	2.0	10	760
1150	46	350	14	500	20	40	20	18	2.0	10	760
1200	48	350	14	500	20	40	20	18	1.9	10	760

1. Movements listed above are based on the Type 31BF, single open arch design. To obtain movements of Type 32BF, multiply single arch values by 2.  
 2. Larger sizes not shown are available upon request.

## Series 30UG Underground Expansion Joint with Floating Flange



### Burial Application

Buried pipelines are directly affected by the external loads produced by weight of earth, traffic load, the ground shifting created by uneven sinking of ground and earthquake. The uneven sinking between rigid structure and ground is most detrimental for underground piping.

To solve such differential settlement problems, Kurbo offers Winflex Series 30UG for direct burial application.

### Type Available

- 31UG & 32UG : Used for standard lateral and axial movements in buried piping.
- 33UG : For absorption of 100mm lateral deflection and normal axial movements
- 34UG : For absorption of 200mm lateral deflection and normal axial movements

### Features

- Absorb ground/foundation settlement and seismic displacements.
- Prevent any damage or breakage of underground pipeline by accommodating the differential settlement caused by earthquake or uneven ground level change
- Designed to withstand external load of over 2 meters of earth weight plus another vehicle load of two 20tons trucks. For greater loads, please contact Kurbo.
- Available in single, double, triple, multiple arch configurations
- Unique ability to accommodate large lateral movement with short overall length.
- Lateral offset capability can be adjusted with longer length.
- The flanges rotate freely on the rubber bellows, compensating for mating flange misalignment Easy handling and installation.
- Specially formulated rubber has great recovery from movement. Unique ability to return to its original shape.
- Excellent corrosion resistance
- No gasket required.

## ***Solution to Differential Settlement Problems:***

*Prevent any damage of underground piping by accommodating differential settlement caused by uneven ground-level change or seismic activity.*

### **Construction**

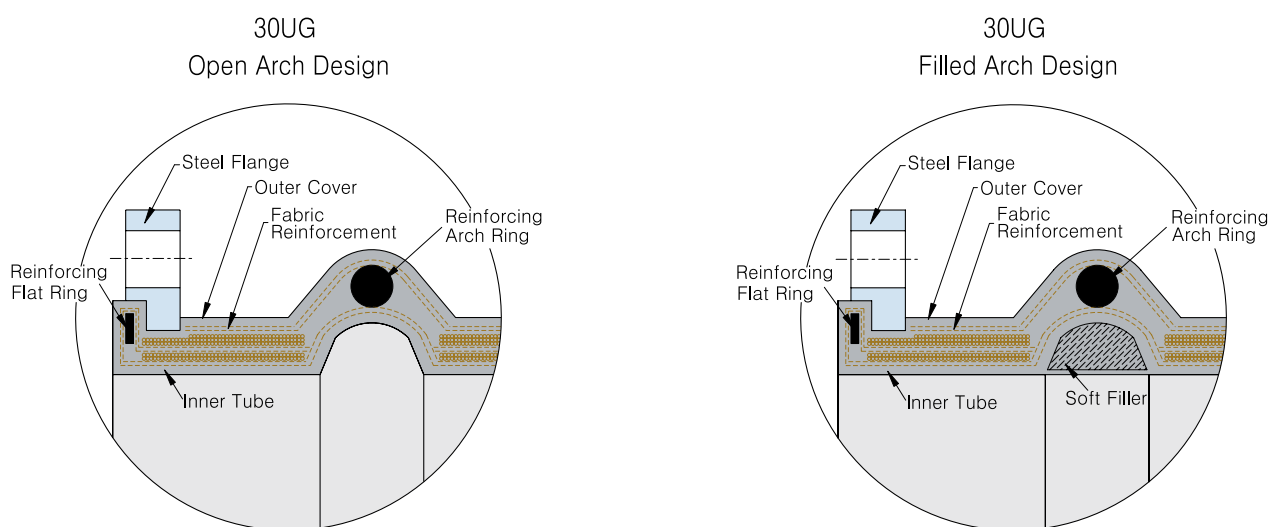

#### **Inner Tube**

The inner tube protects the fabric and metal reinforcements from penetration of the media/fluid .

The smooth, leakproof inner tube can be designed to cover a variety of service conditions for chemical, petroleum, sewage, abrasive and corrosive materials.

#### **Fabric Reinforcement**

The body fabric reinforcement is flexible and supporting member between the inner tube and outer cover. Different fabrics are used depending upon the service conditions such as pressure, temperature. All fabric plies are impregnated with rubber to permit flexibility between the fabric plies

#### **Reinforcing Arch Ring and Wire**

The reinforcing ring at the top of the arch to resist the external forces produced by weight of earth, vehicle load etc. This ring is generally used for direct burial application and vacuum service. In some case, reinforcing steel wires are used over and/or below the fabric plies to provide more strength and rigidity to the expansion joint.

#### **Outer Cover**

The outer cover protects the body fabric and metal reinforcements from external conditions. Generally made of synthetic rubber having good resistance to weather, ozone, aging and corrosion.

#### **Reinforcing Flat Ring**

The reinforcing flat ring imbedded in the rubber packing prevents separation of the steel flange when pressurized and provides tight seal between flanges.

#### **Steel Flange**

The floating flanges allow for mating flange misalignment—Simple installation

## Type 31UG / 32UG Underground Type Joint

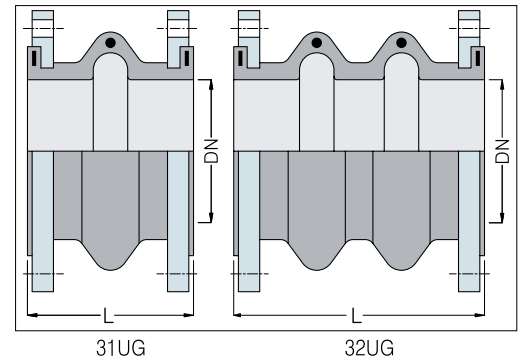

### Type 31UG & 32UG For Normal Movements

Nominal Size		31UG				32UG				Max. Pressure (bar)	Vacuum Rating (mmHg)
		20mm Lateral Deflection			Weight (kg)	50mm Lateral Deflection			Weight (kg)		
DN	inch	L	Comp.	Ext.		L	Comp.	Ext.			
20	0.75	150	20	15	2.2	250	45	30	2.5	10	760
25	1	150	20	15	2.6	250	45	30	2.9	10	760
32	1.25	150	20	15	3.1	250	45	30	3.5	10	760
40	1.5	150	20	15	3.5	250	45	30	4.3	10	760
50	2	150	20	15	4.5	250	45	30	5.1	10	760
65	2.5	150	20	15	5.2	250	45	30	5.9	10	760
80	3	150	20	20	6.1	300	45	30	6.8	10	760
100	4	150	20	20	7.3	300	45	30	8.5	10	760
125	5	150	20	20	10.3	300	45	30	12.7	10	760
150	6	200	20	20	12.7	300	45	30	16.2	10	760
200	8	200	20	20	18.2	300	45	30	23.2	10	760
250	10	200	20	20	27.2	300	45	30	32.4	10	760
300	12	200	20	20	33.4	300	45	30	39.6	10	760
350	14	200	30	25	41.8	350	50	40	51.2	10	760
400	16	200	30	25	49.6	350	50	40	61.8	10	760
450	18	200	30	25	61.3	350	50	40	75.4	10	760
500	20	250	30	25	71.7	350	50	40	88.1	10	760
600	24	250	30	25	98.5	400	50	40	122.4	7	760
700	28	250	30	25	116.5	400	50	40	138.5	7	760
800	32	300	30	25	135.2	400	50	40	157.5	7	760
900	36	300	30	25	152.3	400	50	40	179.3	7	760
1000	40	300	30	25	173.6	450	50	40	196.7	5	760
1100	44	300	30	25	189.3	450	50	40	226.3	5	760
1200	48	300	30	25	218.5	450	50	40	255.3	5	760
1350	54	300	30	25	262.3	450	50	40	301.1	5	760
1500	60	350	30	25	407.8	450	50	40	461.6	5	760

1. Weights are based on KS/JIS 10K flange dimensions, Other flanges are also available
2. Larger sizes than DN1500 are available with Type 21UG or 22UG on request
3. Filled arch design available

## Type 33UG / 34UG Underground Type Joint

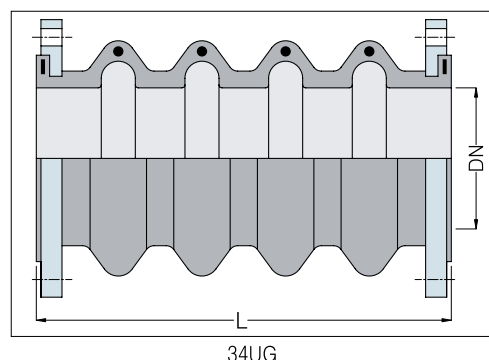

### Type 33UG & 34UG For Large Lateral Movements

Nominal Size		33UG				34UG				Max. Pressure (bar)	Vacuum Rating (mmHg)
		100mm Lateral Deflection			Weight (kg)	200mm Lateral Deflection			Weight (kg)		
DN	inch	L	Comp.	Ext.		L	Comp.	Ext.			
20	0.75	350	60	40	3.3	450	70	50	3.9	10	760
25	1	350	60	40	3.7	450	70	50	4.2	10	760
32	1.25	350	60	40	4.3	450	70	50	5.2	10	760
40	1.5	350	60	40	5.3	450	70	50	6.3	10	760
50	2	350	60	40	6.1	450	70	50	7.5	10	760
65	2.5	350	60	40	8.1	450	70	50	9.6	10	760
80	3	350	60	40	9.2	450	70	50	11.2	10	760
100	4	350	60	40	11.4	450	70	50	13.5	10	760
125	5	350	60	40	15.6	450	70	50	17.8	10	760
150	6	500	60	40	20.7	600	70	50	22.2	10	760
200	8	500	60	40	27.0	600	70	50	28.0	10	760
250	10	500	60	40	37.2	600	70	50	43.8	10	760
300	12	550	60	40	45.9	650	70	50	54.7	10	760
350	14	550	70	50	59.7	650	80	60	70.0	10	760
400	16	550	70	50	75.7	650	80	60	85.7	10	760
450	18	550	70	50	97.2	650	80	60	106.7	10	760
500	20	550	70	50	111.0	650	80	60	126.4	10	760
600	24	550	70	50	144.3	650	80	60	169.5	7	760
700	28	650	70	50	172.3	750	80	60	199.4	7	760
800	32	650	70	50	192.0	750	80	60	226.2	7	760
900	36	650	70	50	221.3	750	80	60	257.5	7	760
1000	40	700	70	50	250.3	800	80	60	289.1	5	760
1100	44	700	70	50	281.3	800	80	60	326.5	5	760
1200	48	700	70	50	312.0	800	80	60	358.7	5	760
1350	54	700	70	50	371.7	800	80	60	422.3	5	760
1500	60	750	70	50	591.9	950	80	60	682.7	5	760

1. Weights are based on KS/JIS 10K flange dimensions, Other flanges are also available
2. Larger sizes than DN1500 are available with Type 23UG or 24UG on request
3. Filled arch design available

# Series 30M Molded Sphere Expansion Joint



### Construction

Long radius spherical molded bellow with high tensile nylon cord and hard wire-reinforced rubber sealing bead.

1. Various elastomers
2. Nylon tire cord
3. Hard steel wire
4. Steel flange
5. Steel ring

### Features

- Higher pressure resistance
- Burst Pressure : -60bars for DN25-DN 150  
-40bars for DN200-DN300
- Excellent absorption of vibration
- Reduces noise and sound transfer
- Small spacer required
- No electrolysis
- Easy installation-Less cost

### Application

- HVAC system
- Compressor lines
- Paper stock lines
- Pump suction and discharge
- Refrigerating lines
- Circulating water lines

### Control Unit Recommendation

Whenever either or both sides of the sphere expansion joint has no firm anchor, Control Units must be installed if surge pressure, pump start-up pressure, test pressure and operating pressure exceed the following figures:

<b>DN</b>	<b>25-100</b>	<b>125-250</b>	<b>300</b>
Pressure(bar)	10	9	6

### Hand -Built Version

For design variations including non-standard face to face length, multiple arch configuration and also for the sizes larger than DN300, we provide Type 21FL or 31FF/32FF which are hand made version of Series 30M.

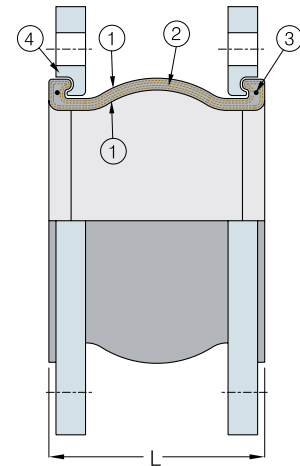

31M-A

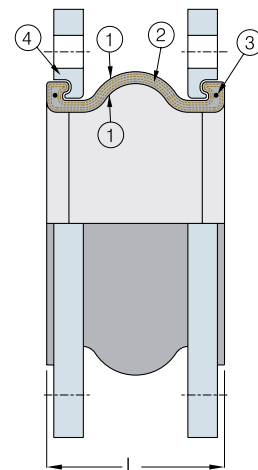

31M-B

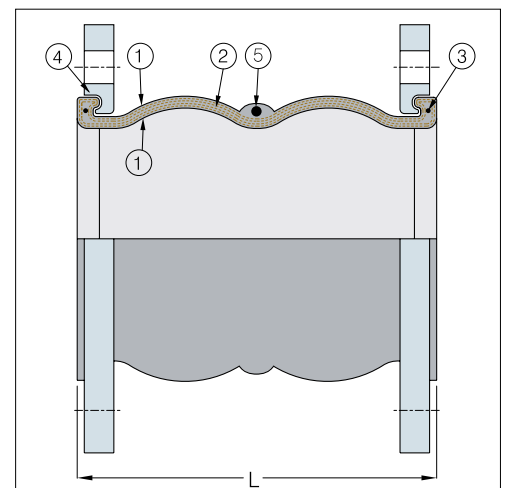

32M-A

### Type 31M-A Single Sphere

Nominal Size		Neutral Length - L		Movement Capability				Max. Pressure (bar)	Vacuum Rating (mmHg)	Approx. Weight (kgs)
				Comp. (mm)	Ext. (mm)	Lat. (mm)	Ang. (deg.)			
DN	inch	mm	inch							
32	1.25	150	6	12	10	12	15	16	660	2.3
40	1.5	150	6	12	10	12	15	16	660	2.7
50	2	150	6	16	12	12	15	16	660	4.0
65	2.5	150	6	16	12	12	15	16	660	5.6
80	3	150	6	16	12	12	15	16	660	6.4
100	4	150	6	16	12	12	15	16	660	8.3
125	5	150	6	16	12	12	15	16	660	10.3
150	6	150	6	16	12	12	15	16	660	12.1
200	8	150	6	16	12	12	15	16	600	18.4
250	10	200	8	18	14	14	15	16	600	25.7
300	12	200	8	18	14	14	15	16	600	37.6

### Type 31M-B Single Sphere

Nominal Size		Neutral Length - L		Movement Capability				Max. Pressure (bar)	Vacuum Rating (mmHg)	Approx. Weight (kgs)
				Comp. (mm)	Ext. (mm)	Lat. (mm)	Ang. (deg.)			
DN	inch	mm	inch							
32	1.25	130	5	12	10	12	15	16	660	2.3
40	1.5	130	5	12	10	12	15	16	660	2.3
50	2	130	5	14	12	12	15	16	660	3.2
65	2.5	130	5	14	12	12	15	16	660	4.8
80	3	130	5	14	12	12	15	16	660	6.0
100	4	130	5	14	12	12	15	16	660	7.5
125	5	130	5	14	12	12	15	16	660	9.2
150	6	130	5	14	12	12	15	16	660	10.3
200	8	130	5	14	12	12	15	16	600	16.1
250	10	130	5	14	12	12	15	16	600	22.3
300	12	130	5	14	12	12	15	16	600	33.3

### Type 32M-A Double Sphere

Nominal Size		Neutral Length - L		Movement Capability				Max. Pressure (bar)	Vacuum Rating (mmHg)	Approx. Weight (kgs)
				Comp. (mm)	Ext. (mm)	Lat. (mm)	Ang. (deg.)			
DN	inch	mm	inch							
32	1.25	175	7	25	16	19	30	16	500	2.5
40	1.5	175	7	25	16	19	30	16	500	3.1
50	2	175	7	25	16	19	30	16	500	4.1
65	2.5	175	7	25	16	19	30	16	500	6.0
80	3	175	7	25	16	19	30	16	500	6.5
100	4	225	9	32	19	25	30	16	450	9.2
125	5	225	9	32	19	25	30	16	450	11.1
150	6	225	9	32	19	25	30	16	450	13.4
200	8	325	13	38	25	32	30	16	450	19.9
250	10	325	13	38	25	32	30	16	450	29.1
300	12	325	13	38	25	32	30	16	450	43.1



## Control Units with Steel Flange Type Expansion Joint

### Control Units

Control units are designed to minimize possible failure of the expansion joint from excessive motions caused by failure of anchoring/guiding, abnormal thermal fluctuation and pressure surge etc. Control unit assemblies can be set at the maximum allowable extension and compression of rubber expansion joint and absorb static pressure thrust developed at the expansion joint. When used in this manner, control units are additional safety factor and can minimize possible damage to adjacent equipment.

### Use of Control Units

Rubber expansion joints must be installed between two fixed anchor points in piping and piping anchors must take end thrusts produced by internal pressure or thermal changes. When it is impossible to provide adequate anchors, control units must be used to restrain the piping system.

***Kurbo supplies various control unit configurations for individual piping system as illustrated on next page.***

### Features

- Protect expansion joints from over-extension and over-compression
- Galvanized carbon steel rods are standard. Stainless steel and other materials available as material selection varies with environmental conditions
- Optional internal nuts or compression sleeves available : To prevent over-compression. Double nuts are recommended for field adjustment and compression sleeve shall be field trimmed.
- Available with rubber washers/grommets : To isolate vibration.
- Available with spherical washers : To prevent binding during offset.
- Available with hinges with integral gusset or separate gusset : To allow for angular movement in one plane.
- Gimbals available : To allow for angular movement in two direction.
- Available with integral flange : To provide equal distribution of forces and prevent stress concentration. Also to prevent any transmission of noise and vibration to mating flange.



HG-S

**GP: Gusset plate with control rod**

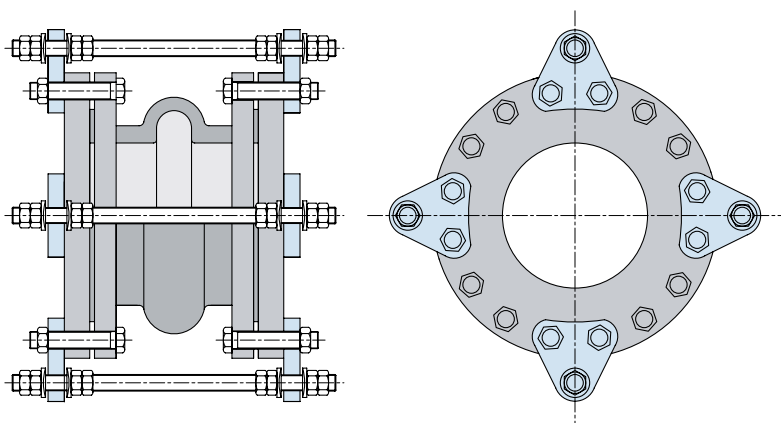

**Type GP**

Gusset plate (control rod plate) with control rod and flat/spherical washer. This type is used for equal dispersion of axial and lateral forces. Compression sleeve can be used to restrain axial compression.

**IF: Integral flange with control rod**

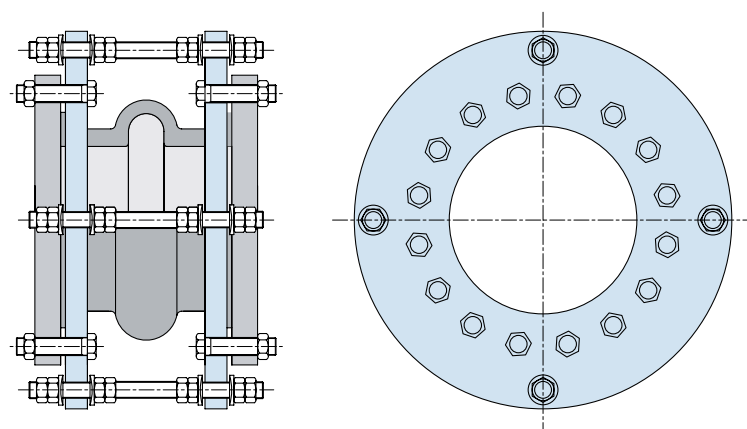

**Type IF**

Integral flange with control rod and optional spherical washer : Used to provide equal distribution of forces and prevent stress concentration. Also for no loads transmission to mating pipe flanges.

**HG-I: Hinge with integral gusset**

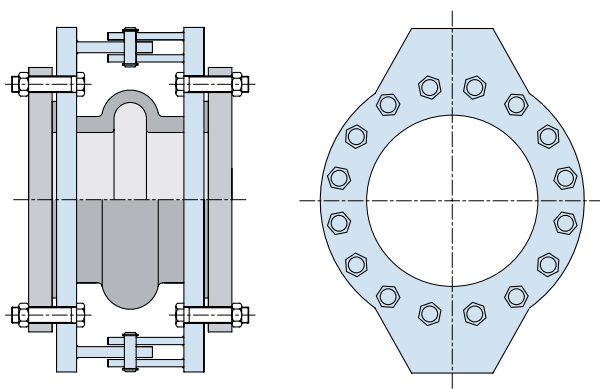

**HG-S: Hinge with separate gusset**

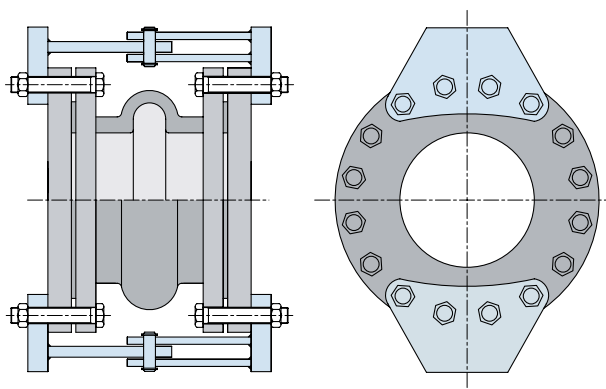

**Type HG-I and Type HG-S**

Hinged expansion joints are used to take up angular movement in one plane. For absorption of lateral movement, 2 hinged expansion joints are required. For large diameter expansion joints, integral flanges can be split in half or more segments. Hinges shall have a pin in a slot on both sides. The slotted hole allows for small amount of axial movement.

**WARNING :** Control Units must be used to protect expansion joints from excessive movements if piping is not properly anchored. Expansion joint may operate in pipelines or equipment carrying fluid and/or gases at elevated temperatures and pressures, so precaution should be taken to make sure these parts are installed and inspected regularly. Care is required to protect personnel in the event of leakage or splash.

## Series 50 Sleeve Type Expansion Joint

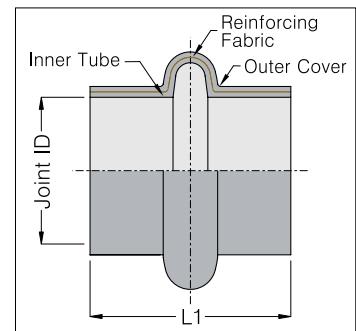

Type 51

### Application

Intended for light weight piping and air, gas ducts on fans, blowers etc. that are subject to low operating pressure and are recommended for gaseous media.

### Features

- Designed to slip over the straight ends of flangeless pipe and be held securely in place with clamps.
- No need for mating flange and hardware—Economical
- Great movement capability with low stiffness and deflection forces
- Wide variety of elastomers available
- 120°C continuous service, 200°C available

### Clamping

- The outside diameter of pipe plus 2mm is recommended for use as inside diameter of sleeve joint.
- Two kinds of clamps made of corrosion protected steel or stainless steel are available : Screw hose clamps for sizes to DN300 and fabricated clamps for DN350 and up.

### Versatile Construction

- Series 50S is standard design with 120°C continuous service.
- Series 50P is pressure/vacuum design.

### Type 51S & 51P

Nominal Size		Joint I.D.	Recommended Length (L1)		Movement Capability			Max. Working Pressure			
								51S		51P	
DN	inch	mm	mm	inch	Comp. (mm)	Ext. (mm)	Lat. (mm)	Positive (bar)	Vacuum (mmHg)	Positive (bar)	Vacuum (mmHg)
40	1.5	50.3	200	8	30	20	20	5	380	8	750
50	2	62.3	200	8	30	20	20	5	380	8	750
65	2.5	75.0	200	8	30	20	20	5	380	8	750
80	3	90.9	200	8	30	20	20	5	380	8	750
100	4	116.3	200	8	30	20	20	4	380	6	750
125	5	143.3	200	8	30	20	20	4	380	6	750
150	6	170.3	200	8	30	20	20	4	380	6	750
200	8	221.1	200	8	30	20	20	2	380	5	750
250	10	275.1	200	8	30	20	20	2	380	5	750
300	12	325.9	200	8	30	20	20	2	380	5	750
350	14	357.6	250	10	40	25	20	2	380	4	750
400	16	408.4	250	10	40	25	20	1	380	4	750
450	18	459.2	250	10	40	25	20	1	380	4	750
500	20	510.0	250	10	40	25	20	1	380	3	750
550	22	560.8	250	10	40	25	20	1	380	3	750
600	24	611.6	250	10	40	25	20	1	380	3	750

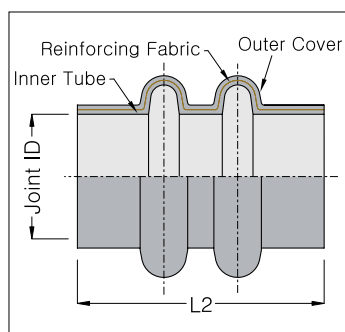

Type 52

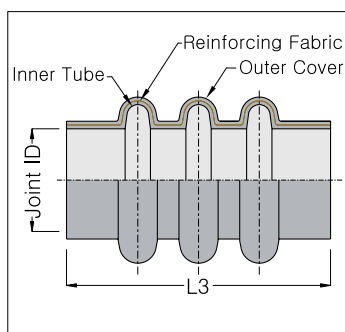

Type 53



### Type 52S & 52P

Nominal Size		Joint I.D.	Recommended Length (L2)		Movement Capability			Max. Working Pressure			
DN	inch		mm	inch	Comp. (mm)	Ext. (mm)	Lat. (mm)	52S		52P	
								Positive (bar)	Vacuum (mmHg)	Positive (bar)	Vacuum (mmHg)
40	1.5	50.3	300	12	60	40	40	5	380	8	730
50	2	62.3	300	12	60	40	40	5	380	8	730
65	2.5	75.0	300	12	60	40	40	5	380	8	730
80	3	90.9	300	12	60	40	40	5	380	8	730
100	4	116.3	300	12	60	40	40	4	380	6	730
125	5	143.3	300	12	60	40	40	4	380	6	730
150	6	170.3	300	12	60	40	40	4	380	6	730
200	8	221.1	300	12	60	40	40	2	380	5	730
250	10	275.1	300	12	60	40	40	2	300	5	730
300	12	325.9	300	12	60	40	40	2	300	5	730
350	14	357.6	350	14	80	50	40	2	250	4	700
400	16	408.4	350	14	80	50	40	1	250	4	700
450	18	459.2	350	14	80	50	40	1	250	4	700
500	20	510.0	350	14	80	50	40	1	250	3	700
550	22	560.8	350	14	80	50	40	1	250	3	700
600	24	611.6	350	14	80	50	40	1	250	3	700

### Type 53S & 53P

Nominal Size		Joint I.D.	Recommended Length (L3)		Movement Capability			Max. Working Pressure			
DN	inch		mm	inch	Comp. (mm)	Ext. (mm)	Lat. (mm)	53S		53P	
								Positive (bar)	Vacuum (mmHg)	Positive (bar)	Vacuum (mmHg)
40	1.5	50.3	350	14	90	60	60	5	250	8	700
50	2	62.3	350	14	90	60	60	5	250	8	700
65	2.5	75.0	350	14	90	60	60	5	250	8	700
80	3	90.9	350	14	90	60	60	5	250	8	700
100	4	116.3	350	14	90	60	60	4	250	6	700
125	5	143.3	350	14	90	60	60	4	250	6	700
150	6	170.3	350	14	90	60	60	4	250	6	700
200	8	221.1	350	14	90	60	60	2	250	5	700
250	10	275.1	350	14	90	60	60	2	250	5	700
300	12	325.9	350	14	90	60	60	2	250	5	700
350	14	357.6	450	18	120	75	60	2	150	4	700
400	16	408.4	450	18	120	75	60	1	150	4	700
450	18	459.2	450	18	120	75	60	1	150	4	700
500	20	510.0	450	18	120	75	60	1	150	3	700
550	22	560.8	450	18	120	75	60	1	150	3	700
600	24	611.6	450	18	120	75	60	1	150	3	700

## Type 60 Pipe Connector



### Application

Kurbo pipe connectors as a vibration dampeners are primarily used to absorb noise and vibration in a piping system and to muffle high frequency oscillations in connecting pumps, compressors and other operating equipments. They are also used to accommodate lateral movement caused by settling and ground motion.

### Construction

Smooth cylindrical connectors with no arch, incorporating full face rubber flange integral with body of the pipe, reinforced with helical steel wire and high tensile fabric provide strength for high pressure operations and prevent collapse under vacuum.

### Movement

Type 60 pipe connectors are suitable only for absorption of lateral and angular movement. They are not designed to absorb expansion, compression axially. For these purposes, use other arch type expansion joints.

### Movement · Pressure · Weight

Nominal Size		Recommended Length		Movement Capability				Max. Pressure (bar)	Vacuum Rating (mmHg)	Weight (kg)	
DN	inch	mm	inch	Comp. (mm)	Ext. (mm)	Lateral (mm)	Angular (deg.)			Pipe Connector	Retaining Ring Set
25	1	300	12	3	3	50	13.3	15	760	0.9	0.8
32	1.25	300	12	3	3	50	10.7	15	760	1.2	1.0
40	1.5	300	12	3	3	45	8.9	15	760	1.4	1.1
50	5	300	12	3	3	45	6.7	15	760	1.8	1.6
65	2.5	300	12	3	3	45	5.4	15	760	2.7	2.2
80	3	450	18	4	4	45	6.0	15	760	4.4	2.3
100	4	450	18	4	4	45	4.5	15	760	5.7	3.3
125	5	600	24	6	6	50	5.4	15	760	9.8	3.5
150	6	600	24	6	6	50	4.5	15	760	11.4	3.9
200	8	600	24	6	6	40	3.4	15	760	16.6	5.9
250	10	600	24	6	6	40	2.7	15	760	19.6	7.8
300	12	600	24	6	6	35	2.3	15	760	27.8	11.4
350	14	600	24	6	6	35	1.9	10	760	34.5	12.7
400	16	600	24	6	6	30	1.7	10	760	39.6	16.0
450	18	600	24	6	6	30	1.5	10	760	40.4	14.7
500	20	600	24	6	6	25	1.4	10	760	46.3	17.9

1. For optimum noise and vibration absorption, use recommended length or longer one
2. Larger sizes available upon request



### Amount of Lateral Displacement by Size and Length

Nominal Size		Lateral Displacement by Length - mm									
DN	inch	300L	350	400	450	500	600	700	800	900	1000
25	1	50	60	65	70	75	80	85	90	95	100
32	1.25	50	65	65	70	75	80	85	90	95	100
40	1.5	45	50	55	60	65	70	75	80	85	90
50	2	45	50	55	60	65	70	75	80	85	90
65	2.5	45	50	55	60	65	70	75	80	85	90
80	3	30	35	40	45	50	55	60	65	70	75
100	4	30	35	40	45	50	55	60	65	70	75
125	5	25	30	35	40	45	50	55	60	65	70
150	6	25	30	35	40	45	50	55	60	65	70
200	8	15	20	25	30	35	40	45	50	55	60
250	10	15	20	25	30	35	40	45	50	55	60
300	12	15	20	24	28	30	35	40	45	50	55
350	14	15	20	24	28	30	35	40	45	50	55
400	16	10	13	16	20	25	30	35	40	45	50
450	18	10	13	16	20	25	30	35	40	45	50
500	20	10	12	15	17	20	25	30	35	40	45

Standard Length of Pipe Connector recommended by Kurbo

### Mechanical Vibration Reduced with Installation of Kurbo Type 60

Pipe System Vibration Frequency	Installation Pipe with :						Remarks
	Type 60-Pipe Connector DN200 X 600mm			Type 21W-Expansion Joint DN200 X 150mm			
	Vibration Reduction at			Vibration Reduction at			
	0.7 bar	3.5 bar	5.5 bar	0.7 bar	3.5 bar	5.5 bar	
40	87%	91%	93%	37%	55%	72%	If DN200 steel piping system had a major vibration frequency of 1000 HZ at 5.5 bar, the installation of pipe connector into the system would reduce vibration 96%.
68	95%	96%	99%	60%	68%	78%	
125	98%	99%	99%	44%	50%	60%	
250	96%	97%	99%	44%	50%	50%	
500	91%	93%	94%	65%	89%	90%	
1000	82%	91%	96%	90%	96%	98%	
2000	99%	99%	99%	94%	95%	96%	
4000	97%	99%	99%	90%	93%	97%	
8000	94%	97%	98%	89%	89%	94%	

## Type 60E Elbow Connector



### Application

Kurbo Elbow Connectors are used in place of metal fittings where high abrasion, tear and chemical resistance is required. In many material transport systems, the bends are sensitive to wear and tear. Kurbo supply an extensive range of pre-formed bends for both suction and discharge purposes, in various sizes and shapes. Kurbo can also offer specialized hose bends outside of the standard bend radii to meet your particular needs with various tube (lining) materials to suit the media within your plant.

The other important function is to provide vibration and stress relief. Many of Kurbo Elbows are found in mining industry.



### Features

- Best choice for noise and vibration control for pumps, compressors and other equipments
- Absorption of thermal movements of piping and accommodation of minor misalignment
- 45° Elbow, 90° Elbow and 90° Long Radius Elbow are available for easy connection.
- Can be manufactured with single arch design in 90° Long Radius Elbow.
- Smooth bore of elbow connector allows for unrestricted flow
- Great flexibility with its shortest dimension
- Excellent abrasion and corrosion resistance
- Integrally flanged design : No gasket required
- Other fittings like Tee, Lateral and Cross are available upon request.

### End Types

#### Beaded (Floating or Swivel Flange) End

These ends are designed as an alternative to fixed flanged ends due to the ability to rotate the floating flange. Beaded end elbow connector has the advantage of ease of alignment of the bolt holes and quick installation in limited space.

#### Flanged End

These ends are recommended for connectors that have medium and high pressures. The rubber and fabric reinforcement of the connector body is extended to form a full face flange. This rubber and fabric flange is backed by split steel retaining ring. Full circle retaining rings are available upon request.

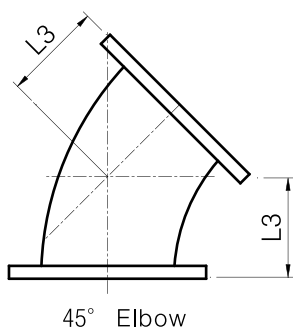
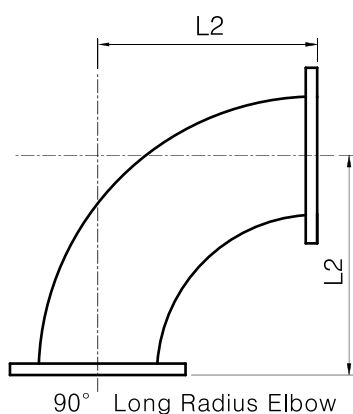
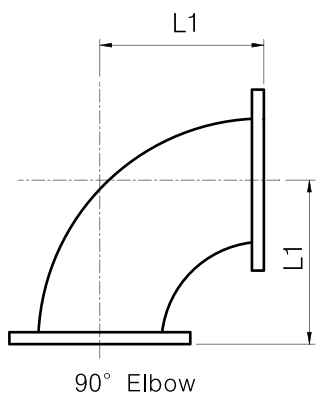

### Material of Construction

#### Elastomers

- Natural rubber, Neoprene, Nitrile, Chlorobutyl, EPDM, CSM.
- Flame resistance rubber and Food grade rubber also available.

#### Reinforcements

- Standard constructions normally utilize high quality nylon tire cord or polyester fabric.
- For extra strength or vacuum service, helical steel wires are embedded in the carcass of elbow connector
- 60E with full vacuum available upon request

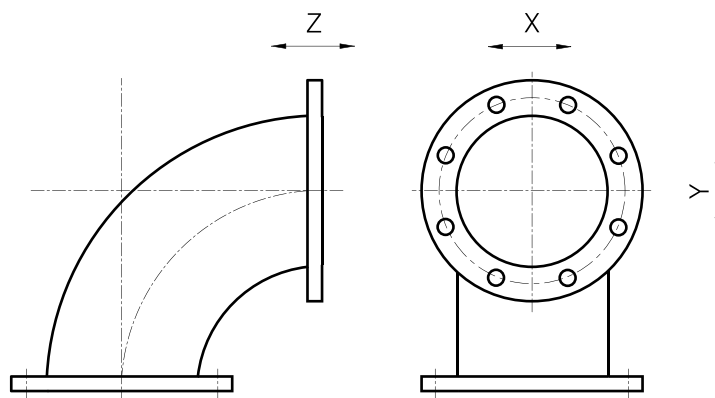

### Movement and Pressure Rating

Nominal Size		Center to Flange			Max. Allowable Movements (mm)			Max. Working Pressure	
		90° Elbow (L1)	90° Long Radius (L2)	45° Elbow (L3)					
DN	inch				X	Y	Z	Positive (bar)	Vacuum (mmHg)
50	2	115	165	70	6	10	10	10	700
65	2.5	125	180	75	6	10	10	10	700
80	3	140	195	80	6	10	10	10	700
100	4	165	245	100	6	10	10	10	700
125	5	190	260	110	6	8	8	10	700
150	6	200	290	120	6	8	8	5	700
200	8	230	355	150	6	8	8	5	660
250	10	280	420	175	6	6	6	5	660
300	12	305	480	200	6	6	6	5	660
350	14	355	570	235	6	6	6	5	660



## Type 70U U-Design Duct Connector

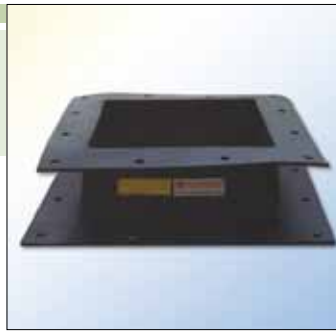

Kurbo offers a wide range of flue duct connectors for flue gas and other ducting applications. Type 70U, U-Design is used for maximum vibration absorption and noise reduction and for normal ducting movements.

### Features

- Available in round or rectangular shape
- Supplied with or without flanges (belt type)
- Typically 6mm thick body reinforced with one or two plies of fabrics.
- Standard designs are rated for  $\pm 0.3$  bars. Higher pressure ratings are available.
- Wide spectrum of elastomers and fabrics to suit most corrosive and temperature environments up to 200°C
- Lower spring rates and deflection forces
- Corners are fully molded with no splices
- Improved corrosion and chemical resistance
- For more extension and compression compensation, Type 70W, W-Design can be provided.

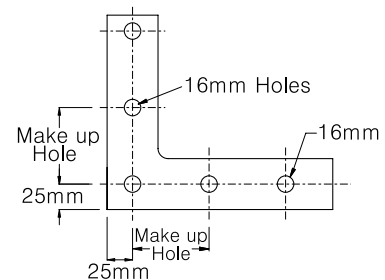

\* Max 100mm Bolt Hole Spacing Recommended

### Rectangular Flange / Corner Detail

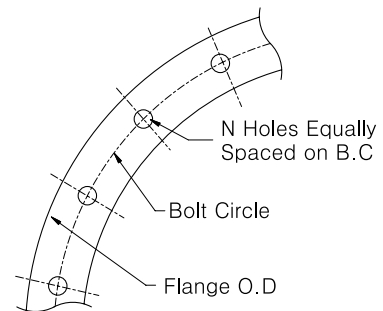

### Round Flange Detail

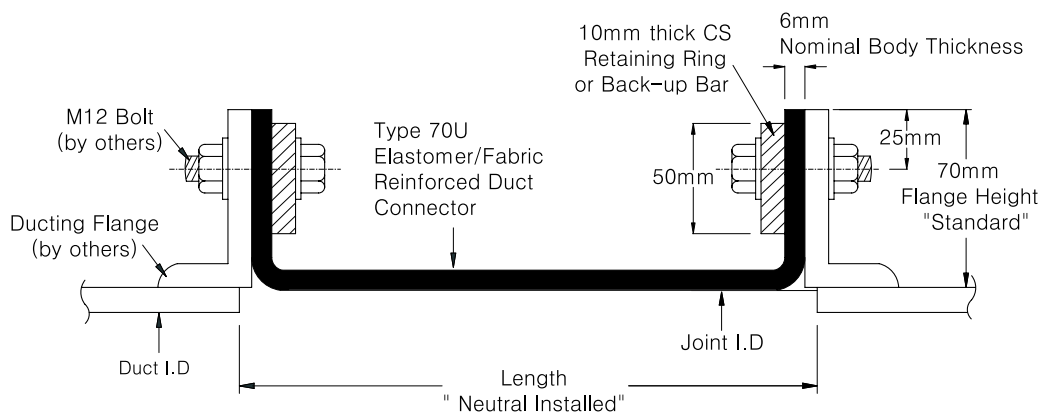

### Maximum Movement Capabilities in mm

150mm(6") Length			230mm(9") Length			300mm(12") Length			400mm(16") Length		
Comp.	Ext.	Lateral.	Comp.	Ext.	Lateral.	Comp.	Ext.	Lateral.	Comp.	Ext.	Lateral.
10	4	10	10	4	15	15	6	20	20	8	25

1. Extension movement capability can be increased with additional pre-compression during installation.
2. For vacuum applications, a setback may be required to keep the duct joint from protruding into the flow stream.

# Type 70V Arch Design Duct Connector



Kurbo offers a wide range of flue duct connectors for flue gas and other ducting applications. Type 70V, Arch-Design is designed for large movement absorption with short overall length.

## Features

- Available in round or rectangular shape
- Supplied with or without flanges(belt type).
- Typically 6mm thick body reinforced with one or two plies of fabrics.
- Standard designs are rated for ±0.3 bars. Higher pressure ratings are available.
- Wide spectrum of elastomers and fabrics to suit most corrosive and temperature environments up to 200°C
- Lower spring rates and deflection forces
- Corners are fully molded with no splices
- Improved corrosion and chemical resistance

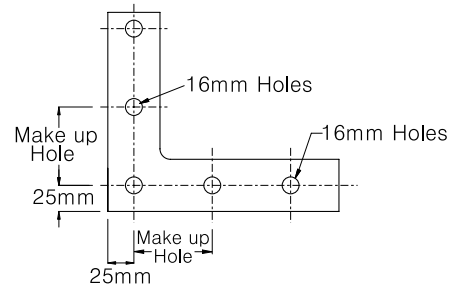

\* Max. 100mm Bolt Hole Spacing Recommended

### Rectangular Flange/Corner Detail

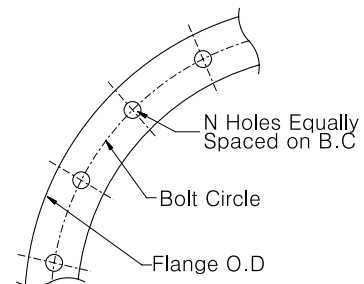

### Round Flange Detail

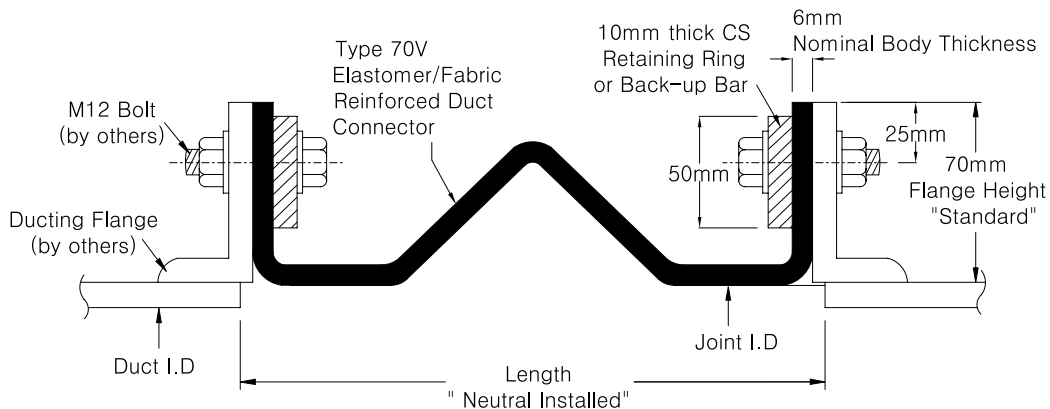

## Maximum Movement Capabilities in mm

150mm(6") Length			230mm(9") Length			300mm(12") Length			400mm(16") Length		
Comp.	Ext.	Lateral.	Comp.	Ext.	Lateral.	Comp.	Ext.	Lateral.	Comp.	Ext.	Lateral.
50	25	25	60	30	35	80	40	45	100	50	55

1. Extension movement capability can be increased with additional pre-compression during installation
2. For vacuum applications, a setback may be required to keep the duct joint from protruding into the flow stream.

## Type 70W W-Design Duct Connector

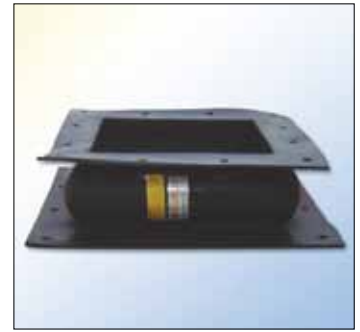

Kurbo offers a wide range of flue duct connectors for flue gas and other ducting applications. Type 70W, W-Design is used for medium ducting movements, noise and vibration reduction.

### Features

- Available in round or rectangular shape
- Supplied with or without flanges (belt type).
- Typically 6mm thick body reinforced with one or two plies of fiberglass, polyester, nylon or Kevlar.
- Standard designs are rated for  $\pm 0.3$  bars. Higher pressure ratings are available.
- Wide spectrum of elastomers and fabrics to suit most corrosive and temperature environments up to 200°C
- Lower spring rates and deflection forces
- For greater extension and compression compensation, Type 70V, arch design can be provided.
- Corners are fully molded with no splices
- Improved corrosion and chemical resistance

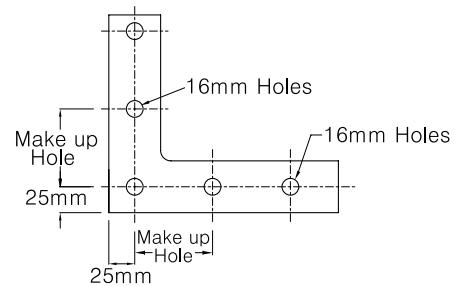

\* Max. 100mm Bolt Hole Spacing

### Rectangular Flange/Corner Detail

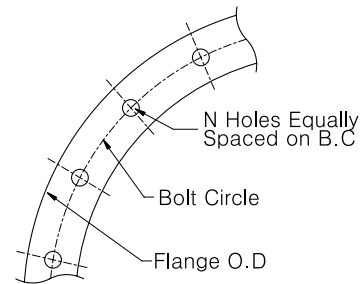

### Round Flange Detail

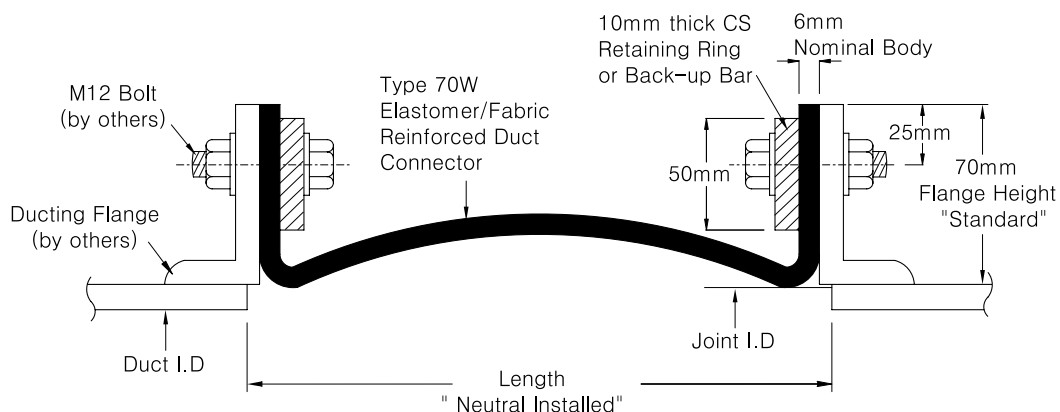

### Maximum Movement Capabilities in mm

150mm(6") Length			230mm(9") Length			300mm(12") Length			400mm(16") Length		
Comp.	Ext.	Lateral.	Comp.	Ext.	Lateral.	Comp.	Ext.	Lateral.	Comp.	Ext.	Lateral.
30	12	20	40	20	30	50	25	40	70	30	50

1. Extension movement capability can be increased with additional pre-compression during installation
2. For vacuum applications, a setback may be required to keep the duct joint from protruding into the flow stream.

## Type 80 Flexible Hose Connector



### Application

Kurbo rubber flexible hose connectors replace metal pipe and are used where a flexible connection is essential and also are used in lines requiring resistance to electrolysis, corrosion, abrasion and severe water hammering. They are also found in piping systems that require noise and vibration isolation and absorption of lateral deflection and flexing caused by thermal changes.

### Construction

Flexible hose body integral with rubber/fabric flange and steel retaining rings. In tough design, extra thick fabric in body and locking flange in rubber flange. Smooth and seamless rubber tube, pressure–vacuum resistant high tensile fabric and evenly spaced heavy duty spiral spring wire reinforcements, tough abrasion and weather resistant rubber cover corrugated for kink resistance.

### Wide Range of Pressure Rating and Size

Kurbo flexible hose connectors are individually designed to have pressure ratings high enough to handle most demanding applications in a very large diameter. Kurbo supply technically superior solutions which are suitable for a wide range of working pressures and all loads.

### Movement

Type 80 hose connectors are suitable only for absorption of lateral and minor angular movement. They are not designed to absorb extension, compression axially. For these purposes, use other arch type expansion joints.

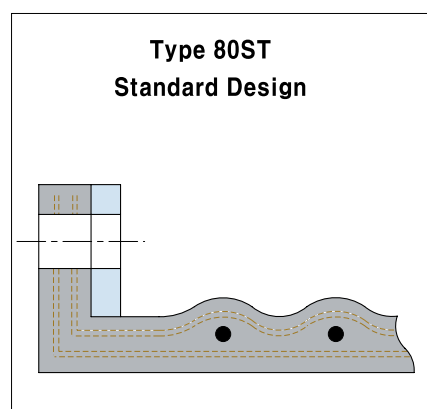

The rubber/fabric flange with a split or full circle steel retaining rings for medium working pressures. Typically the body is reinforced with multiple layers of polyester cord and helical wire

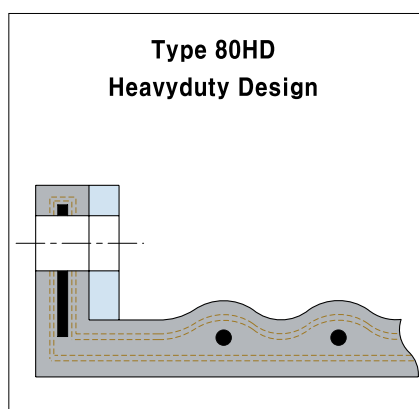

The connectors are fitted with integrated vulcanized rings and/or spirals to withstand higher pressure and vacuum conditions. The main feature of this double flange construction is superior axial strength due to embodied steel flange. The double flanges allow for a large radius in the flange neck, with no cutting forces on the fabric.

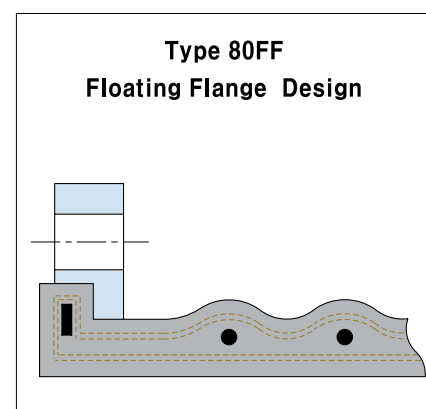

The floating/swivel flange is used with medium pressure service where the bolt holes in pipe flanges are not precisely aligned. The floating flange simplifies fitting between 2 fixed points.

## Type 90A / 90B Pipe Penetration Seal

Kurbo Pipe Penetration Seal is designed to seal pipes passing through walls, floors, tanks. It absorbs all axial, lateral and angular movements caused by medium pipes or by an equipment/structure.

Kurbo pipe penetration seals are available in two types:

Type 90A is designed for large movement absorption. It is ideal for the lines where greater movement and lower forces are required.

Type 90B is used for absorption of normal movements and also for noise and vibration reduction.

### Construction

Standard construction is of EPDM material impregnated with polyester tire cord. EPDM is suitable for most applications in water and provide electric insulation where cathodic protection is required.

### Pressure and Temperature

Sealing pressure capability of standard product : 1.5bars up to DN1000 and 1bar for larger size. For vacuum service, separate supporting ring is required. Maximum operating temperatures to 120°C.

### Features

- Excellent watertight seals between medium pipe and wall pipe sleeve.
- All directional movement capability and lower deflection forces
- Absorbs noise, vibration, ground/foundation settlement
- Flanged or slip-on designs available
- Wide variety of sealing element material
- Multiple arch design of Type 90A provides large axial and lateral movements
- Higher pressure and temperature service available
- Can be custom built specifically to fit your particular application.
- Easy installation and removal: reduce downtime—Most cost effective solution.

### Split Pipe Seal

Supply of split pipe seal is also available to eliminate equipment disassembly reducing costly downtime. Vulcanization of pipe seal can be done on-site.



**Type 90A Pipe Pen Seal**

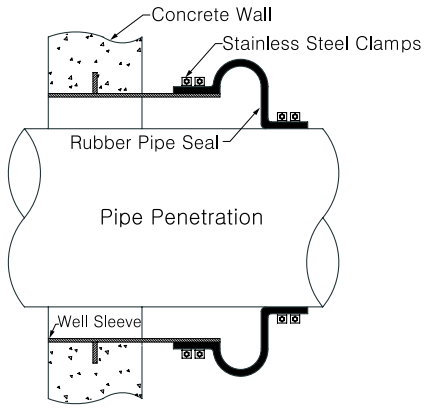

**Slip-on Type**

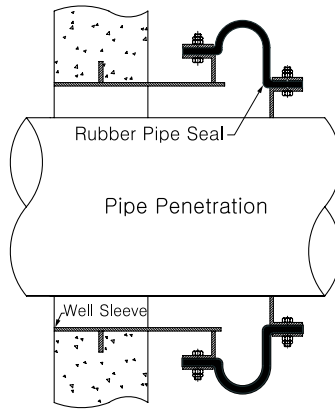

**Belt Type**



**Type 90B Pipe Pen Seal**

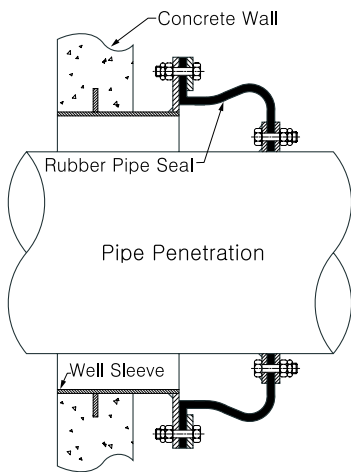

**Integral Flange Type**



# Series 130 PTFE Expansion Joints



### Application

PTFE expansion joints, available in 3 and 5 convolutions, are recommended to handle highly corrosive medias, with glass or plastic piping or in HVAC applications. They are used to absorb thermal changes, vibration and noise and also compensate for line misalignment.

### Features

- Unique protection against chemical, corrosion and high temperatures
- Low spring rates for axial, lateral and angular movements to protect stress sensitive equipment at elevated temperatures.
- High or low temperature performance
- Absorption of large movements with short overall length due to high flexibility.

### Temperature-Pressure

PTFE expansion joints withstand temperatures as high as 230°C and as low as -70°C. Temperatures of the system affect the pressure rating of the expansion joints. For vacuum service, anti-vacuum rings made of stainless steel and encapsulated with PFA tube are put inside the convolution.

**Pressure vs. Temperature - 3 convolution**

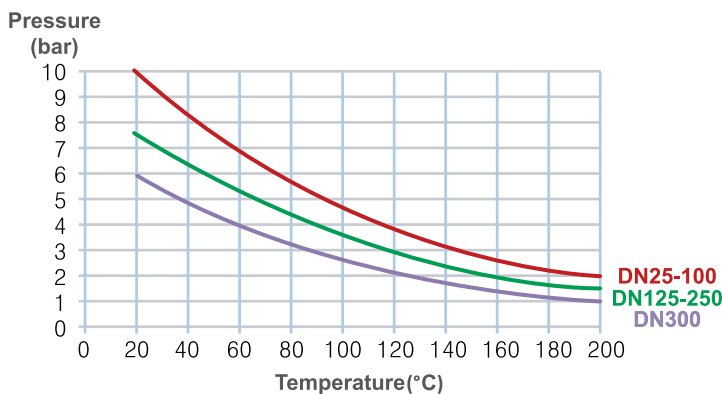

Nominal Size		Type 133 - 3 Convolution					Type 135 - 5 Convolution				
		Neutral Length	Movements(mm)				Neutral Length	Movements(mm)			
DN	inch		Comp.	Ext.	Lat.	Ang.(°)		Comp.	Ext.	Lat.	Ang.(°)
25	1	45	10	10	6	14	75	15	15	10	20
32	1.25	50	10	10	6	14	75	15	15	10	20
40	1.5	60	10	10	6	14	90	15	15	10	20
50	2	70	20	20	10	14	100	25	25	12	20
65	2.5	80	20	20	10	14	115	25	25	12	20
80	3	90	25	25	12	14	125	30	30	16	20
100	4	90	25	25	12	10	135	30	30	16	15
125	5	100	25	25	12	10	150	30	30	16	15
150	6	100	25	25	14	10	150	30	30	16	15
200	8	150	25	25	14	10	200	40	40	16	15
250	10	160	25	25	14	10	220	40	40	16	15
300	12	160	25	25	14	10	230	40	40	16	15

1. Neutral length is set in factory with limit bolts



**WARNING : Always use safety shield in hazardous service**

## Other Specialty Products

Kurbo designs and manufactures wide range of standard expansion joints as well as many specialty items.

Our specialty product lines include :

- Pressure balanced elastomeric expansion joints
- Retrofit (offset) expansion joint
- Internally/externally flanged "U" type joints in rectangular or round
- Substitute rubber joints for metallic universal type/gimbal type expansion joints
- Silicon duct hose
- Dredging hose
- Rubber riser
- Pinch valve sleeve
- And many other industrial applications.





## Labelling System

For product identification, each Kurbo expansion joint is permanently marked or tagged with the following information.

1. Warning instruction
2. Manufacturer's name or trademark
3. Product type number and elastomer material code
4. CE/PED mark and name plate, if applicable
5. Identification serial number

The identification serial number sequence is as follows:

**Example : 24-0310-16-1004**

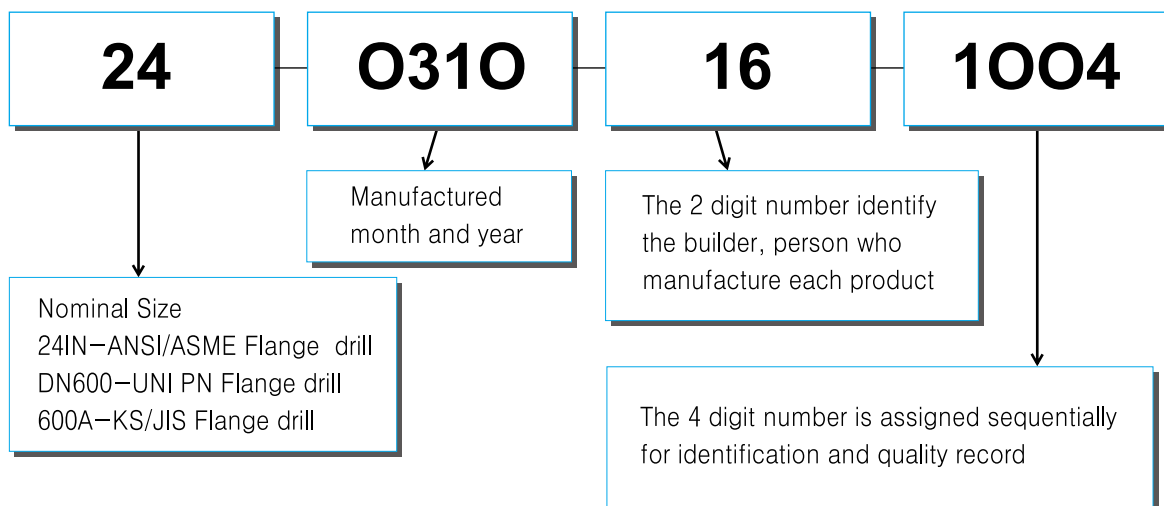

√ **Note** : See dimensional tables for size availability of each type

## Dimension Inspection of Rubber Expansion Joint

Nominal Pipe Size DN / ND		Tolerances(mm) of Rubber Expansion Joint & Pipe Connector							
		Exp Joint ID	Exp Joint OD	Exp Joint BC	Face to Face Length ( L )				Number of Measurements to be averaged
					0 - 150	175 - 300	350 - 450	500 & Up	
mm	inch								
0 - 250	0 - 10	± 4.8	± 6.4	± 4.8	± 4.8	± 4.8	± 4.8	+ 4.8 - 6.4	4
300 - 550	12 - 22	± 6.4	± 9.5	± 6.4	± 4.8	± 4.8	± 4.8	+ 4.8 - 6.4	4
600 - 1150	24 - 46	± 9.5	± 12.7	± 7.9	± 4.8	+ 4.8 - 6.4	± 6.4	± 6.4	4
1200 - 1750	48 - 70	+ 9.5 - 12.7	+ 19 - 12.7	± 9.5	± 6.4	± 9.5	± 9.5	± 9.5	6
1800 & Up	72 & Up	+ 9.5 - 15.8	+ 25.4 - 14.2	± 12.7	± 6.4	± 9.5	± 9.5	± 9.5	6

**Note :** 1. All diameters to be measured with a "Pi" tape.  
2. All dimensions to be an Averaged Reading.

Tolerances of Rubber Flange Thickness		
Flange Thick. - T (mm)	Tolerance (mm)	Number of Measurements
14	± 2	4
16 - 22	± 5	4
25	± 6	4
29 - 32	± 8	5
25 - 35	± 10	6

**Note :** Measurements taken at the bolt hole.

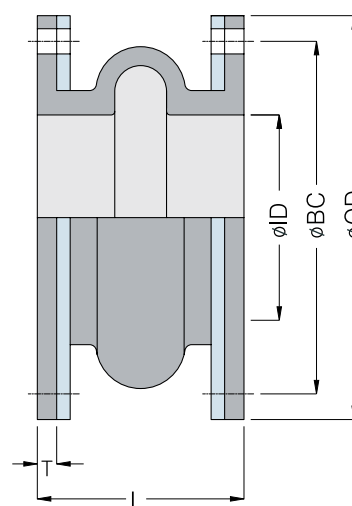

# Installation and Maintenance Guide

## ► Introduction

Proper installation and maintenance in an approved manner are very critical factors so that Kurbo Winflex rubber expansion joints can fulfill their function perfectly. Please be aware that service life of the expansion joint is not only decided by the operating conditions but also by the correct installation and maintenance. The proper location of expansion joints is close to a main anchoring point. Following the expansion joint in the line, pipe guide(s) should be installed to keep the pipe in line and prevent undue displacement of the line. It is typical application of rubber expansion joint to absorb pipeline extension and compression between fixed anchor points. Be sure that special attention be paid to anchor points to ensure safe operation of rubber expansion joints.

## ► Anchoring and Guiding the Piping System

Rubber expansion joints are not designed to take end thrusts nor to sustain piping load. Therefore pipe runs equipped with the expansion joint should be provided with properly designed anchoring points to withstand pressure thrust. If this fact is ignored, premature failure of expansion joint is a foregone conclusion. Figure A illustrates typical piping layout. You will notice that in all cases solid anchoring is provided wherever the pipeline changes direction and that the expansion joints in that line are located as close as possible to those anchor points.

### Main Anchor

Pipe anchors are required at the locations below:

- At changes in direction of the pipe
- At blind ends of pipe
- At major branch connection
- At changes in pipe diameter
- Where a valve is installed between two rubber expansion joints

### Intermediate Anchor

Intermediate section of each rubber expansion joint when 2 or more rubber expansion joints are installed between the main anchors.

### Thrust Calculation

When rubber joints are installed in the pipe line, the static portion of the thrust is calculated as a product of internal arch diameter times the maximum pressure (design or test) that will occur with the line. The result is a force expressed in kgf.

$$T = \frac{\pi}{4} D^2 \cdot P$$

T = Thrust (kg)  
 D = Internal Diameter of Arch (cm)  
 P = Pressure (kg/cm<sup>2</sup>)

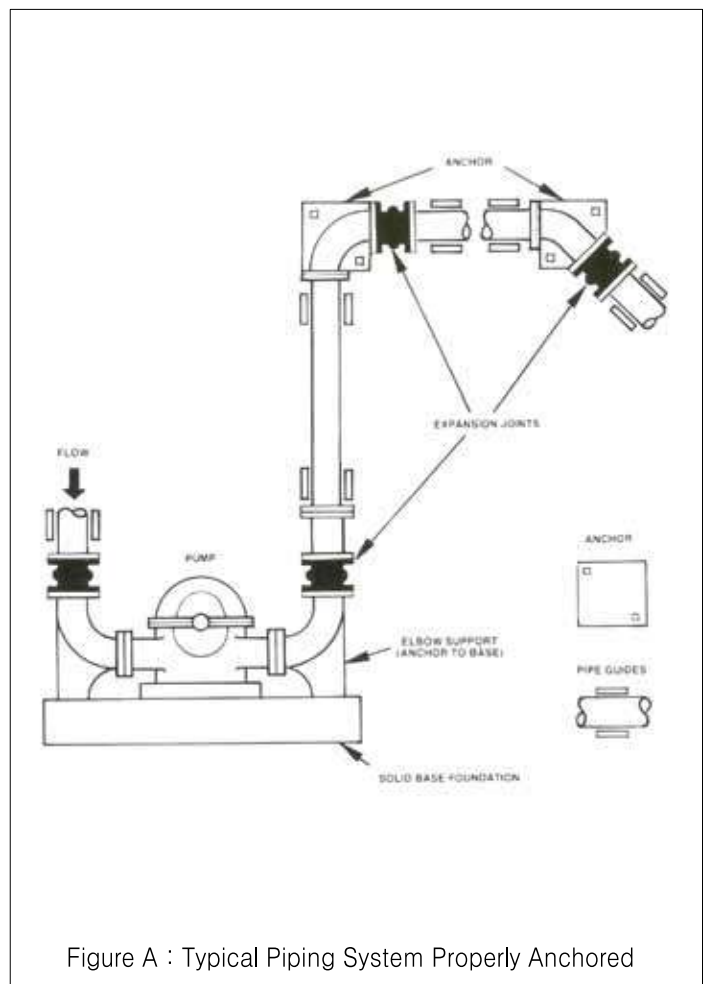

Figure A : Typical Piping System Properly Anchored

## ► Control Rod Units

### Control Units

Control units are designed to minimize possible failure of the expansion joint from excessive motions caused by failure of anchoring/guiding, abnormal thermal fluctuation and pressure surge etc. Control unit assemblies are set at the maximum allowable extension and compression of rubber expansion joint and absorb static pressure thrust developed at the expansion joint. When used in this manner, control units are additional safety factor and can minimize possible damage to adjacent equipment.

### Use of Control Units

Rubber expansion joints must be installed between two fixed anchor points in piping and piping anchors must take end thrusts produced by internal pressure or thermal changes. When it is impossible to provide adequate anchors, control units must be used to restrain the piping system. Besides, control rods should also be used if the piping is not supported enough and on system where wide temperature fluctuations occur. Figure B on the right demonstrates the type of piping connection that must be used in the event it is impossible to employ anchoring.

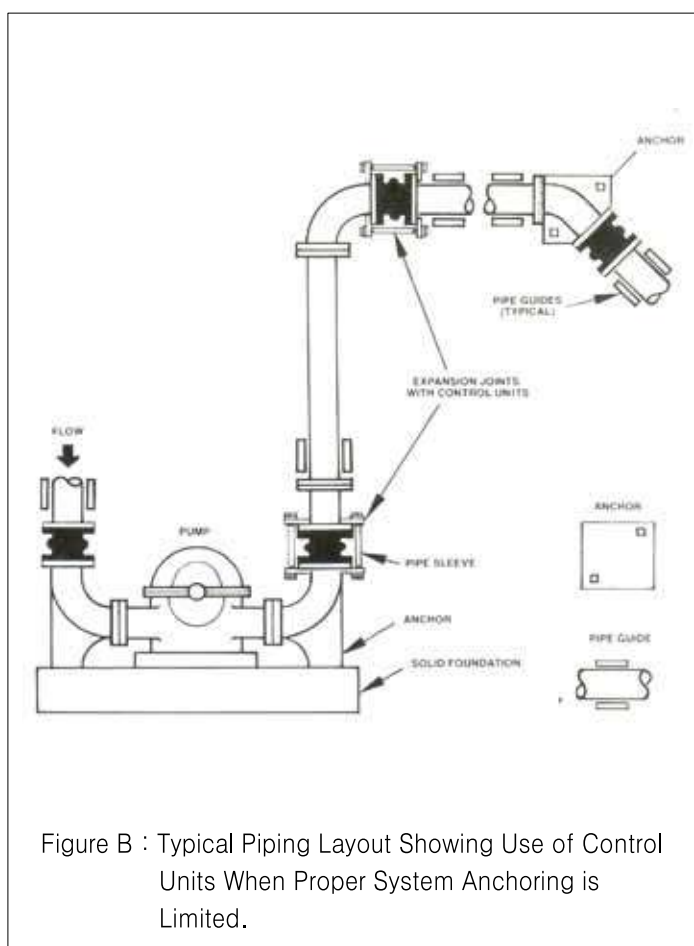

Figure B : Typical Piping Layout Showing Use of Control Units When Proper System Anchoring is Limited.

### Specification of Control Units

For control unit dimensional specifications, please see the "Kurbo Control Unit Dimensions and Rating" on page 39.

*Kurbo supplies various control unit configurations for individual piping system. Please refer to the page 38 and 49.*

## ► Installation Instruction

### Pre-Installation Checks

**1. Service Conditions :** Make sure the Winflex expansion joint ratings for temperature, pressure and movements match the system requirements. Check the elastomer selected is compatible chemically with the process fluid or gas. Please refer to Kurbo "Chemical Resistance Guide" for recommendations.

**2. Anchoring, Guiding, Alignment :** Review the system to ensure that the anchors, supports and alignment guides are properly designed. If the system is not properly anchored and/or guided, control rod unit should be used to protect the expansion joint against excessive axial movements. Expansion joints are normally not designed to make up for piping misalignment errors. Piping should be lined up within 3mm. When pipe misalignment exceeds 3mm, use special offset joint.

**3. Mating Flanges :** Flange type is one of the most important consideration for correct installation and optimum performance of rubber expansion joints. Attention to this is essential to ensure a trouble-free start up, as well as reliable long-term operation. Integral rubber flanges should sound, showing no cutting or gouging by mating flange surfaces. Figure C shows proper connection between mating pipe flange and expansion joint flange.

### Installation

Install the expansion joint against the mating pipe flanges and insert bolt from arch side—set bolt head adjacent to arch. If not possible, make sure that the threaded end of bolt should not come into contact with the arch during operation. Use metal washers over split retaining ring gaps. If not, flange leakage can result. Tighten bolts in stages by alternating around the flange. If the expansion joint has integral rubber flanges like Type 21W, the bolts should be tight enough to make the rubber flange O.D. bulge between the retaining ring and the mating flange. If the joint has metal flanges like Type 31FF, tighten bolts only enough to achieve a seal and never tighten to the point that there is metal-to-metal contact between the joint flange and the mating flange.

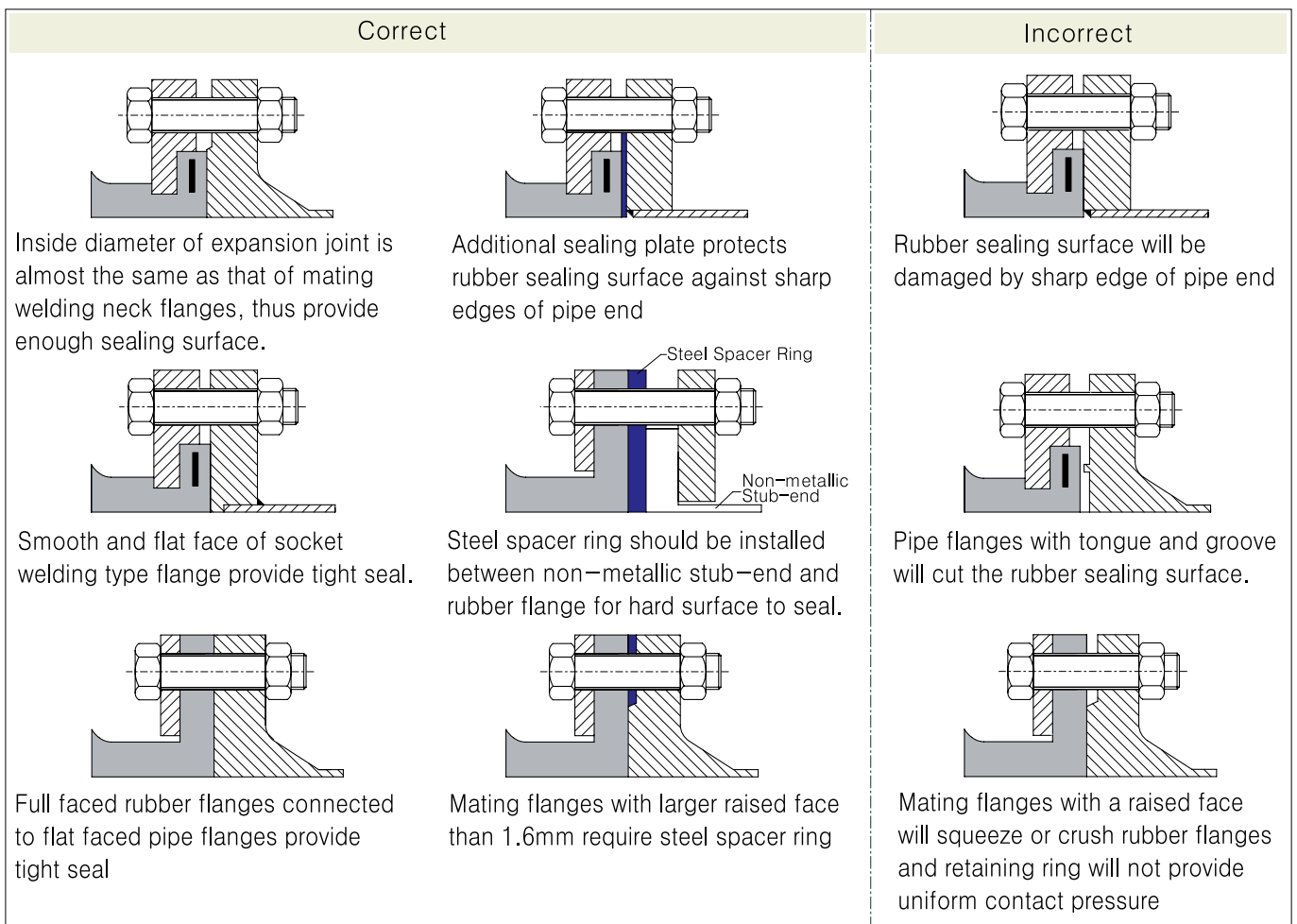

Figure C : Correct Connection to Mating Flanges

## Handling

Do not lift with ropes/bars through the bolt holes. If lifting through the bore, use padding or a saddle to distribute the weight. Make sure cables or forklift tines do not contact the rubber. Do not let expansion joints sit vertically on the edges of the flanges for any period of time.

## Storage

Proper storage helps prolong service life. Expansion joints should be stored in a dry, cool and ventilated dark warehouse. The ideal storage temperature is 10°C to 25°C. Continued exposure to temperature below 0°C and above 30°C should be avoided. It is also recommended that relative humidity be maintained at 20% to 70%.

Do not store rubber expansion joints adjacent to electrical or other equipment that generates ozone. If possible, expansion joint should be stored in their original shipping containers, especially when such containers are wood crates as this would provide protection against the deteriorating affects of oil solvent, corrosive liquids, ozone and sunlight.

Store flange face down on a clean pallet. Do not put other heavy items on top of the joint. Over a period of time, the weight will reduce the face to face length of expansion joint. If storage must be outdoors, the joints should be placed on wooden platforms and should not be in contact with the ground. Cover with a tarpaulin.

## Maintenance

Rubber expansion joints are maintenance free though, they should be inspected periodically in order to ensure proper operation.

### 1. Service Conditions & Dimensions

Check pressure and temperature conditions have not exceeded those for which the expansion joint was designed. Be sure that there is no excessive misalignment between the flanges and installed face to face dimension is correct. Check for over—extension, over—compression, lateral or angular misalignment. The joints operating outside of their rated movement capability are candidates for premature failure.

### 2. Outer Cover

Inspect the cover of the expansion joint for signs of deterioration. Surface crack or crazing in only outer cover is not serious if the underlying fabric is not exposed or cut. Minor cracks could be repaired with rubber cement on site. Cracking where the fabric is exposed and torn indicates the joint should be replaced. Some blisters or deformations on the external portions may not affect proper performance of the joint. These are cosmetic in nature and do not require repair. If the metal reinforcement is visible through the cover, the joint should be replaced shortly. In the full sun or desert—like conditions, periodic recoating of weather resistant paint for UV protection is required.

### 3. Inner Tube

The inner tube should not show signs of excess wear and deterioration. If major blisters, swelling, peeling, deformation and/or fabric ply separations exist in the tube, the expansion joint should be replaced as soon as possible.

### 4. Arch

Excessive ballooning of arch indicates distortion/deterioration of expansion joint strengthening members or excessive system pressure. Service condition should be double—checked and install new joint.

### 5. Flange

Integral rubber flanges should be sound, showing no cutting or gouging by mating flange surfaces. Ply separation at the outside diameter of flange is not a cause for replacement of the joint.

*This guide presents typical rubber expansion joint installations. Contact Kurbo for specific installation details.*

## **Kurbo Expansion Joints Installed in Different Systems**



Type 31FF expansion joint with integral flanges



21W Expansion joints installed in suction and discharge connection at pumping station



Type 70V –Arch design duct connector in line for odor control in sewage treatment plant



Type 23UG Underground expansion joint for Water distribution and wastewater collection system



Typical two arch type expansion joint installation for absorption of great movements.



Type 22EP Externally pressurized expansion joint that may be submerged partially when flooded or in monsoon season



Installation of triple filled arch expansion joint coated with Hypalon paint in recycle pump discharge in FGD system



Type F21W-filled arch type joint in slurry line in thermal power plant.



Viton expansion joints installation. Operating temperature about 180°C and flowing media of sulfuric acid.



## Design, Manufacturing and Testing Capability

### ■ How Kurbo Designs Expansion Joint

Our engineering department's main activity is to design rubber expansion joints that can meet or exceed specific requirements demanded by piping/ducting industry. With exclusive engineering principles and design tools utilizing broad range of international standards such as ASME Code Section VIII, the Standards of Fluid Sealing Association (FSA), the Standards of Expansion Joint Manufacturers Association (EJMA), Pressure Equipment Directive (PED) and other ASTM Standard Specification, Kurbo's all expansion joints are designed and verified through various performance tests. The other responsibility is to design the tooling and equipment needed to manufacture various types of products efficiently and upgrade manufacturing and testing facility to get the highest quality products at the lowest price.



## ■ Preparation of Raw Materials

Elastomeric expansion joints are made of various rubber grades. Rubber compounding is a broad field. Basic elastomers are mixed with a variety of chemicals and ingredients to obtain desired physical properties. Many basic polymers are available that can yield compounds with unique physical properties. To meet high performance and durability demanded by piping industries, Kurbo develops and designs rubber compounds to the specifications required for each application.



After rubber compound is mixed in Banbury, curing agents are added to the rubber batch on the mill, which complete the mixing before material is cut into rough sheets and prepared for the calender.



After milling, the rough sheets are calendered. Powerful steel rollers force rubber into smooth and homogeneous rubber sheet. The precision sheet thickness is assured with the calender machine. This process is critical to tube quality of expansion joint.



With this fabric slitter, Kurbo technician cuts fabrics at precise angles specified by engineer to control swell, elongation and burst in the product. The bias angle can be changed to increase strength or improve flexibility.

## Manufacturing



A years of experience and manufacturing skills are required in fabrication of large diameter hand-built expansion joint. The complexity of the fabrication varies with its size, shape, arch configuration, performance capability and application. Shown on the left is 3000mm diameter exp joint under construction. Kurbo has a broad range of standard designs, but custom design is also one of our work.



The outside cover rubber is pulled up to form the rubber sealing surface before the steel flange template is put in place on a mandrel.

Large reinforcing rings at the top of the arch provide strength enough to withstand external pressures produced by weight of earth, traffic load, ground shifting etc.



After cure, the flange holes are drilled clean with hollow and sharp drill cutter.



After the product with uncured rubber has been built on the mandrel, it is placed in the autoclave for curing. Pressurized steam curing imparts design characteristics of finished product.



About 270 units of mandrels are ready for immediate production when ordered. Various sizes and shapes including concentric/eccentric, elbow and rectangular etc are available. The largest size of mandrel we have is 3600mm diameter.

## ■ Performance Testing

Kurbo's in-plant Performance Testings include hydrostatic testing, full vacuum testing, spring rate testing, deflection testing and life cycle testing. All parts are randomly inspected and tested before shipping. We can provide 100% inspection/test if required.



### Burst Testing

Hydrostatic testing of 2400mm diameter expansion joint . The typical test is 1.5 times design pressure, but the product shown is under burst pressure of 16 bars.



Shown above is 100mm lateral deflection of WinFlex Type 23UG, DN100 x 350mm



Combined deformation test in axial and lateral direction. Available sizes for flex testing are up to DN1650.

### Spring Rate Testing

## ■ Packing and Shipping



Standard wooden crates for shipment



Once final inspection and test required by customers are completed, large size expansion joints are packed securely with plywood prop and then placed in wooden crates for extra protection in transit.



# Technical Information and Reference Data

---

## Contents

	page
▶ <b>General Characteristic and Property of Elastomer</b>	<b>80</b>
▶ <b>Flange Drill Data</b>	<b>82</b>
▶ <b>Unit Conversion</b>	<b>86</b>
▶ <b>Expansion Joint Specification Sheet</b>	<b>88</b>



## General Characteristics and Properties of Elastomers.

The chart below provides general features of the most common elastomers used in manufacture of expansion joints and pipe/duct connectors. For specific chemical, please refer to our "Chemical Resistance Guide" for recommendations on elastomer best suited for the chemical/process fluid in your system or contact Kurbo.

Elastomer	General Properties	General Chemical Resistance	
		Resistant to:	Attacked by:
Gum, Natural Rubber (NR, IR)	Excellent physical properties including abrasion and low temperature resistance. Poor resistance to petroleum based fluids—oils, solvent and many chemicals. Maximum temperature resistance up to 80°C	Most moderate chemicals, wet or dry, organic mild acids, alcohols, salts and ketones. Best selection for abrasion resistance.	Ozone, strong acids, fats, oils, greases, most hydrocarbons. Not recommended where to ozone, oxygen or sunlight.
Neoprene (CR)	Good weather resistance. Excellent flame retarding. Moderate resistance to petroleum based fluids. Continuous operating temperature up to 100°C	Moderate chemicals and acids, ozone, oils, fats, greases, many oils and solvents.	Strong oxidizing acids, esters, ketones. Chlorinated, aromatic and nitro hydrocarbons.
Buna-N (NBR)	Excellent resistance to petroleum-based fluids. Very good resistant against swelling. Operating temperature resistance to 90°C	Generally not affected by solvent, aromatic and aliphatic hydrocarbons, fats, oils, greases, hydraulic fluids,	Ozone (except PVC blends), ketones, esters, aldehydes, chlorinated and nitro hydrocarbons
Buna-S (SBR)	Good physical properties including abrasion resistance. Poor resistance to petroleum based fluids.	Most moderate chemicals, wet or dry, organic acids, alcohols, ketones, aldehydes	Ozone, strong acids, fats, oils, greases, most hydrocarbons
Chlorobutyl (CIIR)	Very good weathering resistance. Excellent dielectric properties. Good heat aging. Low permeability to air and gas. Outstanding dampening characteristics. Poor resistance to petroleum based fluids. Continuous operating temperature up to 120°C.	Animal and vegetable fats, oils, greases, ozone, strong and oxidizing chemicals	Petroleum solvents, coal tar solvents, aromatic hydrocarbons

Rubber compounding is a broad field. Basic elastomers are mixed with a variety of chemicals and ingredients to obtain desired physical properties. Many basic polymers are available that can yield compounds with unique physical properties.

Elastomer	General Properties	General Chemical Resistance	
		Resistant to:	Attacked by:
EPDM (EPDM,EPR)	Excellent ozone, chemical, and aging resistance. Ideal for hot water and steam. Nearly impermeable to gas except for hydrocarbon gases. Poor resistance to petroleum based fluids. Continuous operating temperature up to 120°C.	Animal and vegetable oils, ozone, strong and oxidizing chemicals	Mineral oils and solvents, aromatic hydrocarbons
CSM (known as Hypalon)	Good resistance to oxidizing chemicals such as sulfuric acid. Good aging against solar effects or exposure to petroleum and many of its derivatives. Maximum operating temperature to 110°C.	Ozone, moderate chemical, strong acids, bases, alkaline solutions, freons,hydrogen, aliphatic hydrocarbons.	Chlorinated oxidizing acids, esters, ketones, chlorinated aromatic and nitro hydrocarbons.
Viton (FKM)	Outstanding chemical resistance. Excellent oil resistance both at low and high temperatures. Continuous operating temperature up to 200°C.	All aliphatic, aromatic and halogenated hydrocarbons, acids, animal and vegetable oils	Ketones, low molecular weight esters and nitro- containing compounds
Teflon (AFMU)	Outstanding resistance to most known fluids, chemicals. Continuous operating temperature up to 200°C.	Most chemicals and gases such as sulfur dioxide, concentrated sulfuric acid.	
Silicone (Q, SI)	Excellent high and low temperature properties. Poor resistance to flue gas constituents.	Moderate or oxidizing chemicals, ozone, concentrated sodium hydroxide	Many solvents, oils, concentrated acids, dilute sodium hydroxide

**Note:**

1. The maximum operating temperature resistance is subject to the chemical property of the specific medium pumped, piped through the product.
2. For food service, EPDM and Neoprene compounds are available. Other elastomers can be furnished against batch quantity.
3. For marine service, Special flame retardant neoprene can be furnished to meet U.S. Coast Guard requirements .

# Flange Drilling Data

## ANSI / ASME 150 LBS

Nom. Size		Flange O.D (mm)	Bolt Circle (mm)	No. of Holes	Bolt Hole Dia.
DN	inch				
25	1	108	79.4	4	16
32	1.25	118	88.9	4	16
40	1.5	127	98.4	4	16
50	2	152	120.7	4	19
65	2.5	178	139.7	4	19
80	3	191	152.4	4	19
100	4	229	190.5	8	19
125	5	254	215.9	8	22
150	6	279	241.3	8	22
200	8	343	298.5	8	22
250	10	406	362.0	12	25
300	12	483	431.8	12	25
350	14	533	476.3	12	29
400	16	597	539.8	16	29
450	18	635	577.9	16	32
500	20	699	635.0	20	32
550	22	749	692.2	20	35
600	24	813	749.3	20	35
650	26	870	806.5	24	35
700	28	927	863.6	28	35
750	30	984	914.4	28	35
800	32	1060	977.9	28	41
850	34	1111	1028.7	32	41
900	36	1168	1085.9	32	41
950	38	1238	1149.4	32	41
1000	40	1289	1200.2	36	41
1050	42	1346	1257.3	36	41
1100	44	1403	1314.5	40	41
1150	46	1454	1365.3	40	41
1200	48	1511	1422.4	44	41
1250	50	1568	1479.6	44	48
1300	52	1626	1536.7	44	48
1350	54	1683	1593.9	44	51
1400	56	1746	1651.0	48	48
1450	58	1803	1708.2	48	48
1500	60	1854	1759.0	52	51
1650	66	2032	1930.4	52	51
1800	72	2197	2095.5	60	51
1950	78	2362	2260.6	64	54
2100	84	2534	2425.7	64	54
2250	90	2705	2591.0	68	60
2400	96	2877	2755.9	68	60
2550	102	3048	2908.3	72	67
2700	108	3219	3067.1	72	67
2850	114	3391	3219.5	76	73
3000	120	3562	3371.9	76	73
3300	132	3905	3702.1	80	79
3600	144	4248	4019.6	84	86

## ANSI / ASME 300 LBS

Nom. Size		Flange O.D (mm)	Bolt Circle (mm)	No. of Holes	Bolt Hole Dia.
DN	inch				
25	1	124	88.9	4	19
32	1.25	133	98.6	4	19
40	1.5	156	114.3	4	22
50	2	165	127.0	8	19
65	2.5	190	149.4	8	22
80	3	210	168.1	8	22
100	4	254	200.2	8	22
125	5	279	235.0	8	22
150	6	318	269.9	12	22
200	8	381	330.2	12	25
250	10	445	387.3	16	29
300	12	521	450.9	16	32
350	14	584	514.4	20	32
400	16	648	571.5	20	35
450	18	710	628.7	24	35
500	20	775	685.8	24	35
550	22	838	743.0	24	41
600	24	914	812.8	24	41
650	26	972	876.3	28	44
700	28	1035	939.8	28	44
750	30	1092	997.0	28	48
800	32	1149	1054.1	28	51
850	34	1207	1104.9	28	51
900	36	1270	1168.4	32	54
950	38	1168	1092.2	32	41
1000	40	1238	1155.7	32	44
1050	42	1289	1206.5	32	44
1100	44	1353	1263.7	32	48
1150	46	1416	1320.8	28	51
1200	48	1467	1371.6	32	51
1250	50	1530	1428.8	32	54
1300	52	1581	1479.6	32	54
1350	54	1657	1549.4	28	61
1400	56	1708	1600.2	28	61
1450	58	1759	1651.0	32	61
1500	60	1810	1701.8	32	61

Note :

Flange dimensions shown are in accordance with ANSI/ASME B16.5 Class 150 & 300 and ANSI/ASME B16.47 Class 150 & 300, Series A and AWWA C207 Class D 150lbs.

**API 605 150 LBS**

Nom. Size		Flange O.D (mm)	Bolt Circle (mm)	No. of Holes	Bolt Hole Dia.
DN	inch				
650	26	786	744.5	36	22
700	28	837	795.3	40	22
750	30	887	846.1	44	22
800	32	941	900.2	48	22
850	34	1005	957.3	40	25
900	36	1057	1009.7	44	25
950	38	1124	1069.8	40	28
1000	40	1175	1120.6	44	28
1050	42	1226	1171.4	48	28
1100	44	1276	1222.2	52	28
1150	46	1341	1284.2	40	32
1200	48	1392	1335.0	44	32
1250	50	1443	1385.8	48	32
1300	52	1494	1436.6	52	32
1350	54	1549	1492.3	56	32
1400	56	1600	1543.1	60	32
1450	58	1675	1611.4	48	35
1500	60	1726	1662.2	52	35

**PN 6**

Nom. Size		Flange O.D (mm)	Bolt Circle (mm)	No. of Holes	Bolt Hole Dia.
DN	inch				
25	1	100	75	4	11
32	1.25	120	90	4	14
40	1.5	130	100	4	14
50	2	140	110	4	14
65	2.5	160	130	4	14
80	3	190	150	4	18
100	4	210	170	4	18
125	5	240	200	8	18
150	6	265	225	8	18
200	8	320	280	8	18
250	10	375	335	12	18
300	12	440	395	12	22
350	14	490	445	12	22
400	16	540	495	16	22
450	18	595	550	16	22
500	20	645	600	20	22
550	22	700	655	20	26
600	24	755	705	20	26
650	26	810	760	20	26
700	28	860	810	24	26
750	30	920	865	24	30
800	32	975	920	24	30
900	36	1075	1020	24	30
1000	40	1175	1120	28	30
1100	44	1305	1240	28	33
1200	48	1405	1340	32	33
1300	52	1520	1450	32	36
1400	56	1630	1560	36	36
1500	60	1730	1660	36	36
1600	64	1830	1760	40	36
1800	72	2045	1970	44	39
2000	80	2265	2180	48	42
2200	88	2475	2390	52	42
2400	96	2685	2600	56	42
2600	104	2905	2810	60	48
2800	112	3115	3020	64	48
3000	120	3305	3220	68	48

**API 605 300 LBS**

Nom. Size		Flange O.D (mm)	Bolt Circle (mm)	No. of Holes	Bolt Hole Dia.
DN	inch				
650	26	867	803.1	32	35
700	28	921	857.3	36	35
750	30	991	920.8	36	38
800	32	1054	977.9	32	41
850	34	1108	1031.7	36	41
900	36	1171	1089.2	32	44
950	38	1222	1140.0	36	44
1000	40	1273	1190.8	40	44
1050	42	1334	1244.6	36	48
1100	44	1384	1295.4	40	48
1150	46	1461	1365.3	36	51
1200	48	1511	1416.1	40	51
1250	50	1562	1466.9	44	51
1300	52	1613	1517.7	48	51
1350	54	1673	1577.8	48	51
1400	56	1765	1651.0	36	60
1450	58	1827	1713.0	40	60
1500	60	1878	1763.8	40	60

Note :

Flange dimensions shown are in accordance with ANSI/ASME B16.47 Class 150 & Class 300, Series B.

# Flange Drilling Data

## PN 10

Nom. Size		Flange O.D (mm)	Bolt Circle (mm)	No. of Holes	Bolt Hole Dia.
DN	inch				
25	1	115	85	4	14
32	1.25	140	100	4	18
40	1.5	150	110	4	18
50	2	165	125	4	18
65	2.5	185	145	4	18
80	3	200	160	8	18
100	4	220	180	8	18
125	5	250	210	8	18
150	6	285	240	8	22
200	8	340	295	8	22
250	10	395	350	12	22
300	12	445	400	12	22
350	14	505	460	16	22
400	16	565	515	16	26
450	18	615	565	20	26
500	20	670	620	20	26
550	22	730	675	20	30
600	24	780	725	20	30
650	26	835	780	24	30
700	28	895	840	24	30
750	30	965	900	24	33
800	32	1015	950	24	33
900	36	1115	1050	28	33
1000	40	1230	1160	28	36
1100	44	1340	1270	32	36
1200	48	1455	1380	32	39
1300	52	1575	1490	32	42
1400	56	1675	1590	36	42
1500	60	1785	1700	36	42
1600	64	1915	1820	40	48
1800	72	2115	2020	44	48
2000	80	2325	2230	48	48
2200	88	2550	2440	52	56
2400	96	2760	2650	56	56
2600	104	2960	2850	60	56
2800	112	3180	3070	64	56
3000	120	3405	3290	68	62

## PN 16

Nom. Size		Flange O.D (mm)	Bolt Circle (mm)	No. of Holes	Bolt Hole Dia.
DN	inch				
25	1	115	85	4	14
32	1.25	140	100	4	18
40	1.5	150	110	4	18
50	2	165	125	4	18
65	2.5	185	145	4	18
80	3	200	160	8	18
100	4	220	180	8	18
125	5	250	210	8	18
150	6	285	240	8	22
200	8	340	295	12	22
250	10	405	355	12	26
300	12	460	410	12	26
350	14	520	470	16	26
400	16	580	525	16	30
450	18	640	585	20	30
500	20	715	650	20	33
550	22	775	710	20	33
600	24	840	770	20	36
650	26	860	790	24	36
700	28	910	840	24	36
750	30	970	900	24	36
800	32	1025	950	24	39
900	36	1125	1050	28	39
1000	40	1255	1170	28	42
1100	44	1365	1270	32	42
1200	48	1485	1390	32	48
1300	52	1585	1490	32	48
1400	56	1685	1590	36	48
1500	60	1820	1710	36	56
1600	64	1930	1820	40	56
1800	72	2130	2020	44	56
2000	80	2345	2230	48	62
2200	88	2555	2440	52	62
2400	96	2765	2650	56	62
2600	104	2965	2850	60	62

**KS / JIS 5K**

Nom. Size		Flange O.D (mm)	Bolt Circle (mm)	No. of Holes	Bolt Hole Dia.
DN	inch				
25	1	95	75	4	12
32	1.25	115	90	4	15
40	1.5	120	95	4	15
50	2	130	105	4	15
65	2.5	155	130	4	15
80	3	180	145	4	19
100	4	200	165	8	19
125	5	235	200	8	19
150	6	265	230	8	19
200	8	320	280	8	23
250	10	385	345	12	23
300	12	430	390	12	23
350	14	480	435	12	25
400	16	540	495	16	25
450	18	605	555	16	25
500	20	655	605	20	25
550	22	720	665	20	27
600	24	770	715	20	27
650	26	825	770	24	27
700	28	875	820	24	27
750	30	945	880	24	33
800	32	995	930	24	33
850	34	1045	980	24	33
900	36	1095	1030	24	33
1000	40	1195	1130	28	33
1100	44	1305	1240	28	33
1200	48	1420	1350	32	33
1350	54	1575	1505	32	33
1500	60	1730	1660	36	33

**KS / JIS 10K**

Nom. Size		Flange O.D (mm)	Bolt Circle (mm)	No. of Holes	Bolt Hole Dia.
DN	inch				
25	1	125	90	4	19
32	1.25	135	100	4	19
40	1.5	140	105	4	19
50	2	155	120	4	19
65	2.5	175	140	4	19
80	3	185	150	8	19
100	4	210	175	8	19
125	5	250	210	8	23
150	6	280	240	8	23
200	8	330	290	12	23
250	10	400	355	12	25
300	12	445	400	16	25
350	14	490	445	16	25
400	16	560	510	16	27
450	18	620	565	20	27
500	20	675	620	20	27
550	22	745	680	20	33
600	24	795	730	24	33
650	26	845	780	24	33
700	28	905	840	24	33
750	30	970	900	24	33
800	32	1020	950	28	33
850	34	1070	1000	28	33
900	36	1120	1050	28	33
1000	40	1235	1160	28	39
1100	44	1345	1270	28	39
1200	48	1465	1380	32	39
1350	54	1630	1540	36	46
1500	60	1795	1700	40	46

**JWWA 7.5K**

Nom. Size		Flange O.D (mm)	Bolt Circle (mm)	No. of Holes	Bolt Hole Dia.
DN	inch				
80	3	211	168	4	19
100	4	238	195	4	19
125	5	263	220	6	19
150	6	290	247	6	19
200	8	342	299	8	19
250	10	410	360	8	23
300	12	464	414	10	23
350	14	530	472	10	25
400	16	582	524	12	25
450	18	652	585	12	25
500	20	706	639	12	27
600	24	810	743	16	27
700	28	928	854	16	33
800	32	1034	960	20	33

Nom. Size		Flange O.D (mm)	Bolt Circle (mm)	No. of Holes	Bolt Hole Dia.
DN	inch				
900	36	1156	1073	20	33
1000	40	1262	1179	24	33
1100	44	1366	1283	24	33
1200	48	1470	1387	28	33
1350	54	1642	1552	28	39
1500	60	1800	1710	32	39
1600	64	1915	1820	36	39
1650	66	1965	1870	40	39
1800	72	2115	2020	44	39
2000	80	2326	2230	48	46
2100	84	2430	2335	48	46
2200	88	2550	2440	52	46
2400	96	2760	2650	56	46
2600	104	2960	2850	56	52

# Unit Conversion

## Pressure

Atm.	Bar	Kg/cm <sup>2</sup>	PSI	MPa	Mercury		Water Column		
					mmHg	inHg	mAq	inAq	ftAq
1	1.013	1.033	14.70	0.10133	760.0	29.9	10.3	406.8	33.9
0.98692	1	1.01972	14.50	0.10000	750.1	29.5	10.2	401.5	33.5
0.96784	0.98067	1	14.22	0.09807	735.6	29.0	10.0	393.7	32.8
0.06805	0.06895	0.07031	1	0.00689	51.7	2.0	0.7	27.7	2.3
9.87	10.00	10.19	145.05	1	7.50X10 <sup>3</sup>	2.95X10 <sup>2</sup>	1.02X10 <sup>2</sup>	4.01X10 <sup>3</sup>	3.35X10 <sup>2</sup>
0.00132	0.00133	0.00136	0.01934	0.00013	1	0.039	0.014	0.535	0.045
0.03342	0.03386	0.03453	0.49115	0.00339	25.4	1	0.345	13.6	1.133
0.09678	0.09807	0.10000	1.42233	0.00981	73.6	2.896	1	39.4	3.281
0.00246	0.00249	0.00254	0.03613	0.00025	1.9	0.074	0.025	1	0.083
0.02950	0.02989	0.03048	0.43353	0.00299	22.4	0.883	304.8	12.0	1

## Metric to PSI

bar	MPa	PSI	bar	MPa	PSI	Kg/cm <sup>2</sup>	MPa	PSI	Kg/cm <sup>2</sup>	MPa	PSI
1	0.1	14.5	21	2.1	304.6	1	0.10	14.2	21	2.06	298.7
2	0.2	29.0	22	2.2	319.1	2	0.20	28.4	22	2.16	312.9
3	0.3	43.5	23	2.3	333.6	3	0.29	42.7	23	2.26	327.1
4	0.4	58.0	24	2.4	348.1	4	0.39	56.9	24	2.35	341.4
5	0.5	72.5	25	2.5	362.6	5	0.49	71.1	25	2.45	355.6
6	0.6	87.0	26	2.6	377.1	6	0.59	85.3	26	2.55	369.8
7	0.7	101.5	27	2.7	391.6	7	0.69	99.6	27	2.65	384.0
8	0.8	116.0	28	2.8	406.1	8	0.78	113.8	28	2.75	398.3
9	0.9	130.5	29	2.9	420.6	9	0.88	128.0	29	2.84	412.5
10	1.0	145.0	30	3.0	435.1	10	0.98	142.2	30	2.94	426.7
11	1.1	159.5	31	3.1	449.6	11	1.08	156.5	31	3.04	440.9
12	1.2	174.0	32	3.2	464.1	12	1.18	170.7	32	3.14	455.1
13	1.3	188.5	33	3.3	478.6	13	1.27	184.9	33	3.24	469.4
14	1.4	203.1	34	3.4	493.1	14	1.37	199.1	34	3.33	483.6
15	1.5	217.6	35	3.5	507.6	15	1.47	213.4	35	3.43	497.8
16	1.6	232.1	36	3.6	522.1	16	1.57	227.6	36	3.53	512.0
17	1.7	246.6	37	3.7	536.6	17	1.67	241.8	37	3.63	526.3
18	1.8	261.1	38	3.8	551.1	18	1.77	256.0	38	3.73	540.5
19	1.9	275.6	39	3.9	565.6	19	1.86	270.2	39	3.82	554.7
20	2.0	290.1	40	4.0	580.2	20	1.96	284.5	40	3.92	568.9

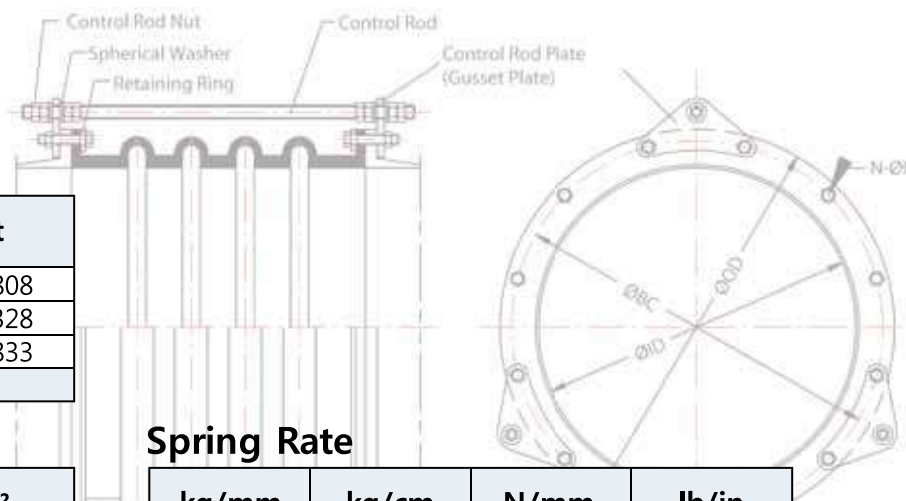

### Length

m	cm	in	ft
1	100	39.37	3.2808
0.01	1	0.3937	0.0328
0.0254	2.54	1	0.0833
0.3048	30.48	12	1

### Area

m <sup>2</sup>	cm <sup>2</sup>	in <sup>2</sup>	ft <sup>2</sup>
1	10000	1550	10.76
0.00010	1	0.155	0.00108
0.00065	6.45	1	0.00694
0.09290	929.03	144	1

### Spring Rate

kg/mm	kg/cm	N/mm	lb/in
1	10	9.81	56
0.1	1	0.981	5.6
0.10197	1.0197	1	5.7
0.01786	0.1786	0.1751	1

### Force

kg	lb	N	poundal
1	2.20	9.81	70.93
0.45359	1	4.45	32.17
0.10197	0.22481	1	7.23
0.01410	0.03108	0.13826	1

### Torque

kg-m	in-lb	ft-lb	Nm
1	86.80	7.23	9.81
0.01152	1	0.08333	0.11299
0.13826	12	1	1.36
0.10197	8.85	0.7376	1

### PSI to Metric

PSI	bar	MPa	PSI	bar	MPa
10	0.69	0.07	210	14.48	1.45
20	1.38	0.14	220	15.17	1.52
30	2.07	0.21	230	15.86	1.59
40	2.76	0.28	240	16.55	1.65
50	3.45	0.34	250	17.24	1.72
60	4.14	0.41	260	17.93	1.79
70	4.83	0.48	270	18.62	1.86
80	5.52	0.55	280	19.31	1.93
90	6.21	0.62	290	19.99	2.00
100	6.89	0.69	300	20.68	2.07
110	7.58	0.76	350	24.13	2.41
120	8.27	0.83	400	27.58	2.76
130	8.96	0.90	450	31.03	3.10
140	9.65	0.97	500	34.47	3.45
150	10.34	1.03	550	37.92	3.79
160	11.03	1.10	600	41.37	4.14
170	11.72	1.17	700	48.26	4.83
180	12.41	1.24	800	55.16	5.52
190	13.10	1.31	900	62.05	6.21
200	13.79	1.38	1000	68.95	6.89

### Velocity

m/s	km/h	ft/s	ft/h	mile/h
1	3.6	3.3	11811	2.23694
0.27778	1	0.91134	3280.8	0.62137
0.30480	1.10	1	3600	0.68182
0.00009	0.00031	0.00028	1	0.00019
0.44704	1.61	1.47	5280	1

### Volume

m <sup>3</sup>	cm <sup>3</sup>	in <sup>3</sup>	ft <sup>3</sup>	gal
1	1000000	61023.74	35.31	264.17
0.000001	1	0.061024	0.000035	0.000264
0.000016	16.39	1	0.000579	0.004329
0.028317	28316.85	1728	1	7.48
0.003785	3785.41	231	0.133681	1

### Volume Flow Rate

m <sup>3</sup> /s	l/s	l/min	m <sup>3</sup> /h	ft <sup>3</sup> /s
1	1000	60000	60	35.3
0.001	1	60	3.6	0.03531
0.000017	0.01666	1	0.06	0.00059
0.000277	0.27778	16.67	1	0.00981
0.028320	28.32	1698.33	101.9	1



KURBO EXPANSION JOINT SPECIFICATION SHEET		YOUR CUSTOMER					
YOUR COMPANY	company name:	date					
	mailing address:	page: of					
	city, state, zip code:	project name:					
	name of person submitting data:	inquiry/job number:					
	e-mail	delivery required:					
	phone no.	item no. tag no.	item no. tag no.	item no. tag no.	item no. tag no.	item no. tag no.	item no. tag no.
SIZE	<b>pipe size of application:</b> nominal pipe size or the inside diameter of the connecting pipe flange	quantity required		quantity required		quantity required	
	<b>installed length:</b> is the space between connecting pipe flanges. indicate limitations, if any	mm	mm	mm	mm	mm	mm
FLOWING MEDIUM	<b>flowing medium:</b> indicate chemical. if flowing medium is corrosive, abrasive, or viscous. explain in detail						
	<b>type of medium:</b> indicate if liquid, gas, slurry, solids, etc						
	<b>temperature of flowing medium:</b> indicate both operating and maximum temperatures at the expansion joint	operate	maximum	operate	maximum	operate	maximum
		°C	°C	°C	°C	°C	°C
	<b>temperature of surrounding atmosphere:</b> indicate both minimum and maximum temperatures of atmosphere at the expansion joint	minimum	maximum	minimum	maximum	minimum	maximum
	°C	°C	°C	°C	°C	°C	
	<b>time duration at maximum temperature:</b> indicate length of time						
	<b>velocity of flowing medium:</b> in meter per second	m/sec		m/sec		m/sec	
PRESSURES	<b>operating pressure at the joint:</b> actual pressure in which system works in normal conditions	positive	negative	positive	negative	positive	negative
		bar	mmHg	bar	mmHg	bar	mmHg
	<b>design pressure of the system:</b> highest/most severe pressure expected during operation	positive	negative	positive	negative	positive	negative
		bar	mmHg	bar	mmHg	bar	mmHg
	<b>surge pressure of the system:</b> increased pressure due to pump starts, valve closings, etc.	positive	negative	positive	negative	positive	negative
	bar	mmHg	bar	mmHg	bar	mmHg	
<b>test pressure of the system:</b> hydrostatic test used to demonstrate system capability	positive	negative	positive	negative	positive	negative	
	bar	mmHg	bar	mmHg	bar	mmHg	
	<b>type of pressure:</b> constant, intermittent, shock, pulsating, etc.						
MOVEMENTS	<b>axial compression at joint:</b> in mm as a result of pipe extension	mm		mm		mm	
	<b>axial extension at joint:</b> in mm as a result of pipe contraction	mm		mm		mm	
	<b>lateral deflection at joint:</b> in mm	mm		mm		mm	
	<b>angular movement at joint:</b> in degrees	degrees		degrees		degrees	
	<b>torsional movement at joint:</b> in degrees	degrees		degrees		degrees	
MISCELLANEOUS	<b>pipe flange drilling:</b> indicate specific standard such as ANSI, AWWA, UNI, DIN, BS, KS, JIS. if special provide: flange O.D., bolt circle, number and size of holes	specification		specification		specification	
	<b>mating pipe flange thickness and material:</b>	mm		mm		mm	
	<b>location of joint installation:</b> indoors or outdoors						
	<b>retaining rings:</b> are required on all installations. Reusable, they need not be ordered with replacement or spare expansion joints	yes or no		yes or no		yes or no	
<b>control unit assemblies:</b> are recommended for use in all expansion joint applications. Control units must be used when piping support or anchoring is insufficient	yes or no		yes or no		yes or no		
<b>hydrostatic test of joint required:</b>	yes or no		yes or no		yes or no		

# Complete Line of Kurbo Expansion Joints



Rubber Expansion Joint



Metal Expansion Joint

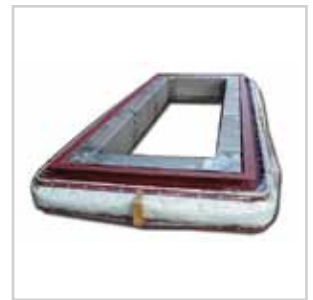

Fabric Expansion Joint



PTFE Lined Expansion Joint



PTFE Expansion Joint



Flexible Joint



Flexible Metal Hose







# winflex

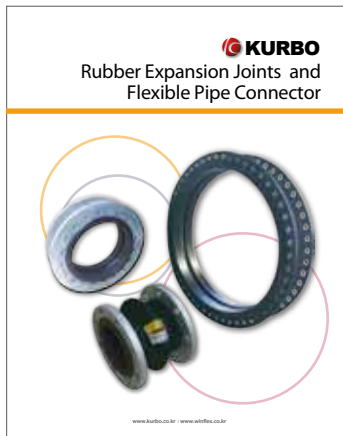

Specialist of Rubber Expansion Joint, Metal Expansion Joint,  
Fabric Expansion Joint, PTFE Expansion Joint, Flexible Metal Hose  
and other flexible products

Kurbo Company Limited  
1504-8 Songjeong-dong, Gangseo-gu, Busan 618-817, Korea  
Tel +82-51-831 1291 / Fax +82-51-831 1295  
www.kurbo.co.kr www.winflex.co.kr Email: kurbo@kurbo.co.kr